

SunRanger® Seasonal Tilt Model ST-16XL 500W Series

Panel dimensions vary by manufacturer;
verify compatibility before installation.

Assembly Procedure



Table of Contents

Pre-Project Checklist	4
Foundation Options	5
Helical Screw Pile Layout	7
Base Beam Installation	8
Base Beam Add-on	9
Pivot Plates	11
Leg Beams	12
Main Beams	13
Cross Cables	14
Support Cables	15
Purlin Location	16-17
Purlin Troughs	18
Micro-inverter Placement	19
Solar Module Installation	20, 22-27
Panel Bolting Detail	21
Micro-inverter Connection	28
High-Wind Support	29-30
Micro-inverter Connection Map	31-34
Post-Installation Checklist	35
Seasonal Adjustment Dates	36

Pre-Project Checklist

Before beginning installation, be sure you have completed the following:

- Obtain necessary development/building permits, if applicable. Please check with your municipal office to confirm if additional permits are needed.
- Request line locates before beginning any ground-work or trenching.
- Remove serial number stickers from each micro-inverters prior to installing and place on the micro-inverter connection map (found on Pg. 32) in a corresponding manner to how they are installed on the system—this is to ensure the layout in your monitoring app accurately reflects your system.
- When preparing to install your system, lay all materials out first to allow for a simplified set-up. Secure your pallet(s) of panels; as you remove panels, the remainder may tip over and shatter if not secured.
- Before beginning your installation, please read pages 19, 22 and 24 to ensure you have a thorough understanding of the correct procedure.

Important Notes & Recommendations

- If you are completing a self-installation, **you will need at least 2-3 people** as some components are quite heavy and will need to be maneuvered throughout the process.
- If you are completing the electrical work yourself, you will need to obtain disconnect stickers from a certified electrician. These will be required to pass your electrical inspection after project completion.
- Plan your work and follow safety precautions. Use eye protection, hearing protection and a hard hat during the installation.
- You may find it beneficial to have a 110V outlet installed in your solar system breaker panel, to plug in tools or your DTU/ECU.
- Remote monitoring may not function if your system is too far from your wi-fi source or does not have a clear line-of-sight. To avoid issues, consider running an underground ethernet cable when trenching to connect the system directly.

Should you have any questions during the installation process or if you require assistance, please contact our office at 403-236-5501

Foundation Options for SunRanger

The SunRanger can be adapted to attach to most foundation types:

Helical Screw Pile

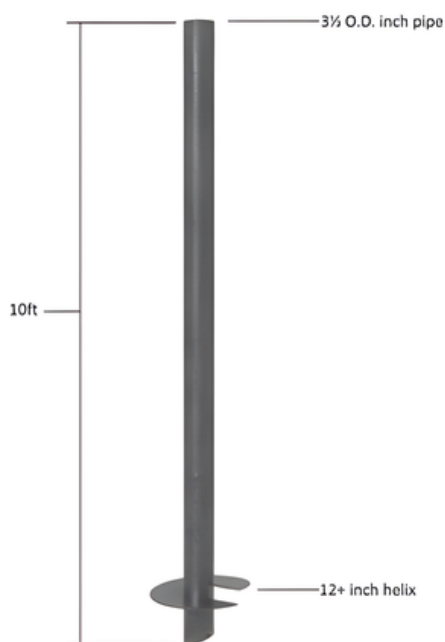

Steel Pipe in Concrete

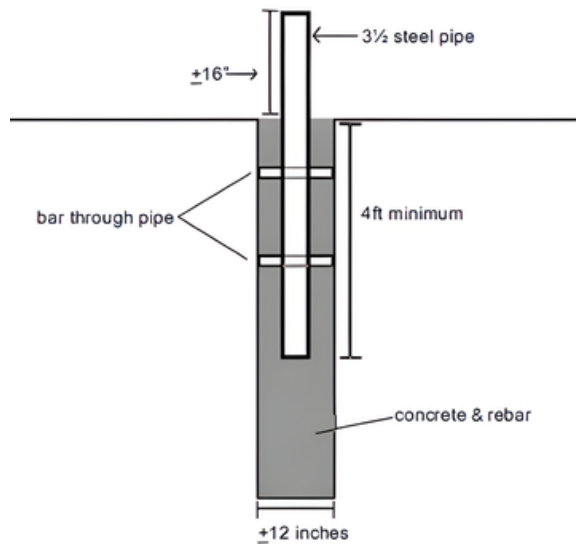

Concrete Block Foundation

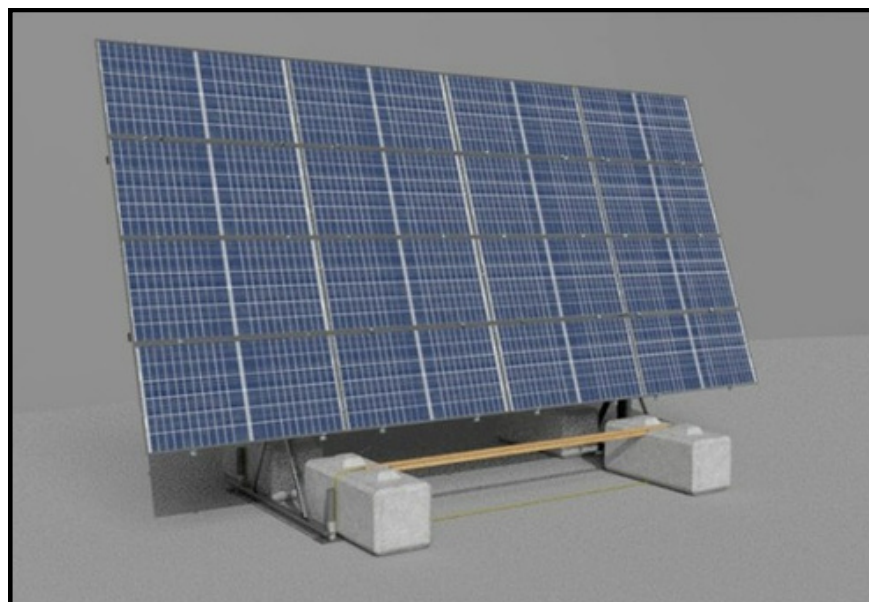

Foundation Loads for SunRanger

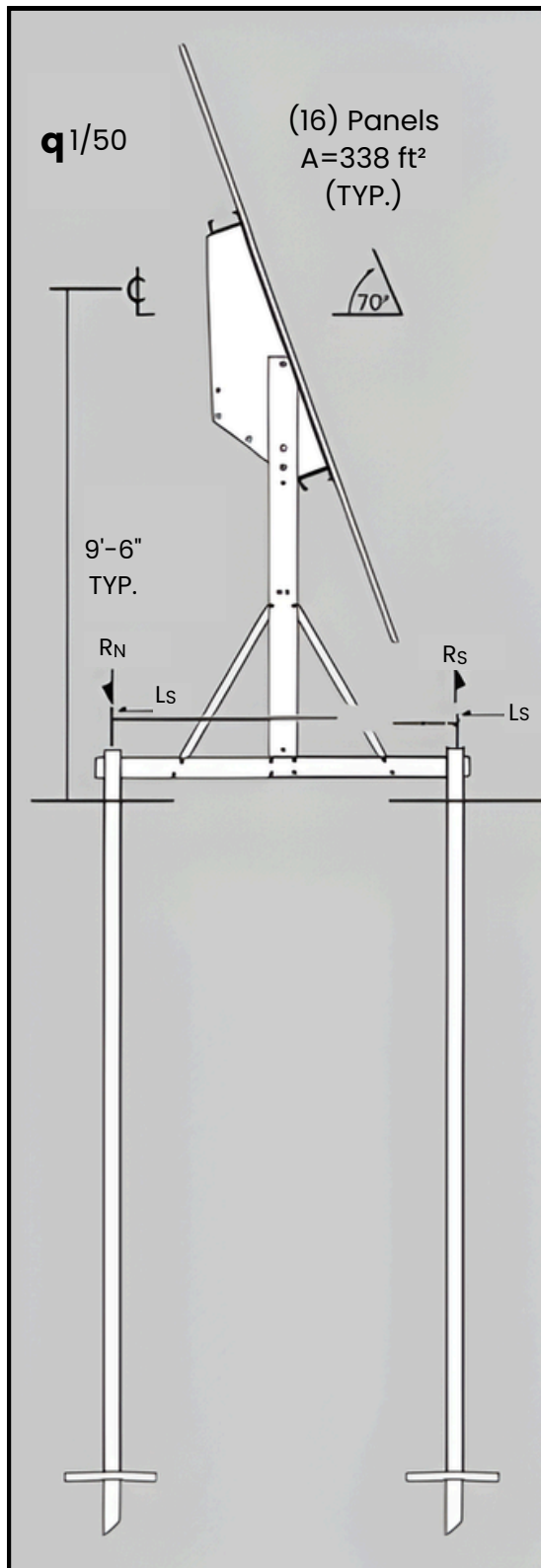

Hourly Wind Press., $q^{1/50}$ (kPa)	equiv. vel. (kph)	Unfactored Vert. Resist. Per anchor (+/- lbf)	Unfactored Lat. Resist. Per anchor (+/- lbf)
0.30	80	1790	650
0.35	86	2145	760
0.40	92	2500	865
0.45	98	2855	975
0.50	103	3210	1085
0.55	108	3565	1190
0.60	113	3920	1300
0.65	117	4275	1410
0.70	122	4630	1515
0.75	126	4985	1625
0.80	130	5340	1735
0.85	134	5700	1840
0.90	138	6050	1950

As per 4.1.3.2.4 of the National Building Code, if overturning, uplift, or sliding is to be countered by ballast weight, 0.9 of that weight should be considered as acting in that regard.

0.9 of the self-weight of the rack and PV modules has been applied to the required resistances provided.

IMPORTANT

Foundation requirements will vary by location and soil condition. Verify foundation type and capacity by a qualified foundation professional or installer.

Helical Screw Pile Layout

Step 1:

Before beginning XL rack assembly, ensure that the screw-piles have been installed as per the layout diagram below.

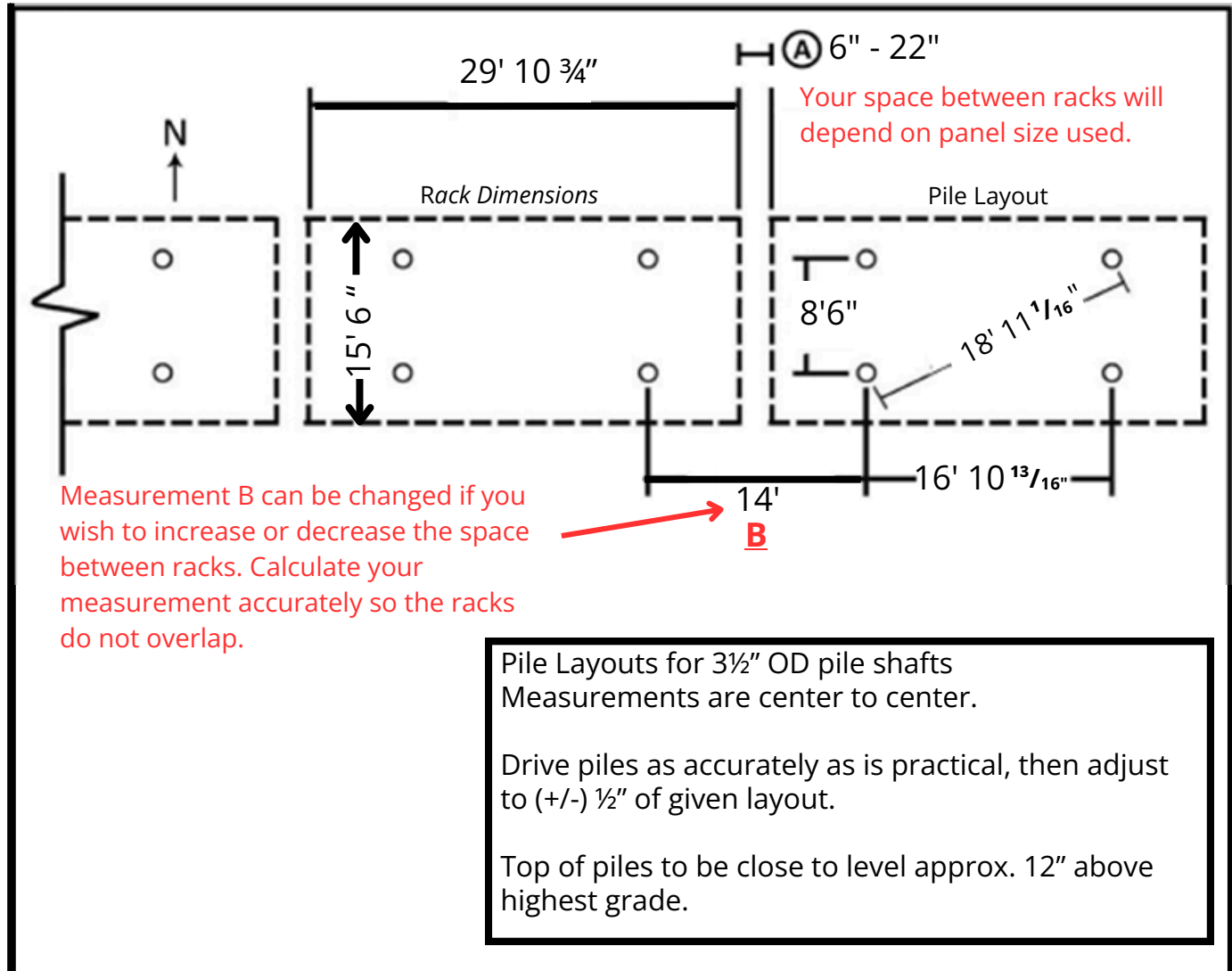

Ⓐ The distance between solar units will vary depending on the type and size of solar panels used, this space may vary between 6" - 22".

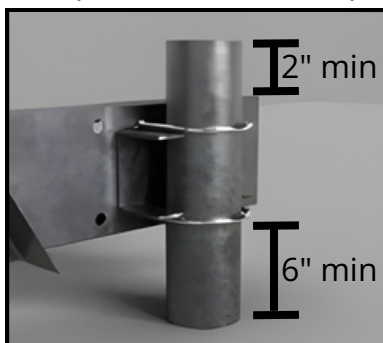

Allow sufficient pile length so the leg beam is not on the ground or too close to the top of the pile.

Base Beam Installation

Step 2:

If you are installing multiple racks in a line, all of the base beams should be at a similar elevation to prevent shading. To do so, **start with the rack where the ground is highest.**

Attach the base beams to the piles using the U-bolts and saddles. These two beams go on the outside of the piles with the flat sides facing toward each other. Ensure that the angled holes are oriented as shown in the top picture.

The two hole beams must be level and at the same elevation. Some dunnage (pieces of wood) under the beam may be helpful in steadying them at the correct height. Once the beams have been accurately positioned, tighten the U-bolts.

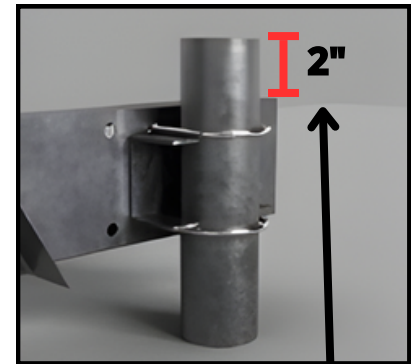
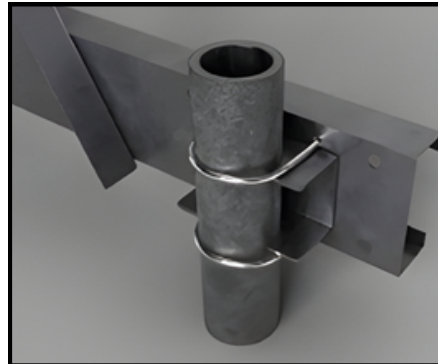
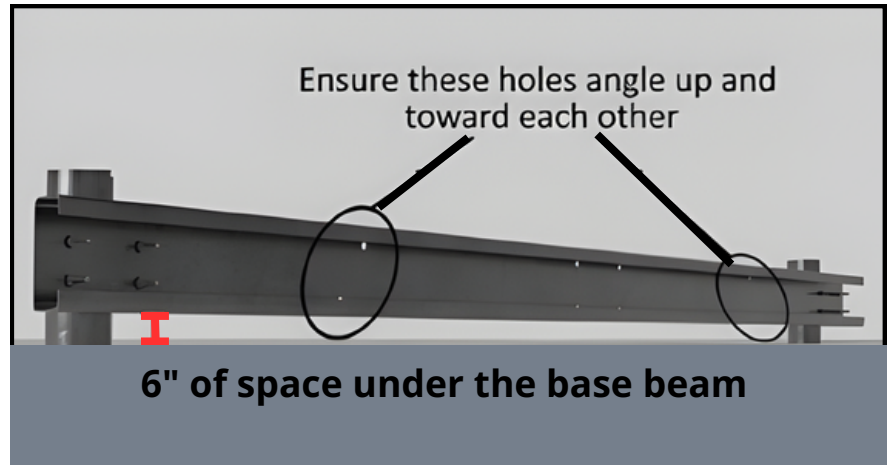

Top of U-bolt should be a minimum of 2" below the top of pile.



6" of clear space under the base beam should be provided to prevent frost heave from pushing up on the beam.

Important Note: The "long end" of base beam should be installed on the "North" pile location



Base Beam Add-on

IMPORTANT NOTE: ALL PARTS ARE LASER-ETCHED WITH DIRECTIONAL POSITIONING—EAST AND WEST

A) Drill $11/32$ " size hole in the slot provided through the screw pile.



B) Do not over size the hole. The $3/8$ bolt provided is a thread cutting bolt and will need to be installed with an impact wrench.



C) Install a $3/8$ bolt and washer provided with Loctite on threads.



D) Tighten bolt with impact wrench (Loctite optional)



Leveling Base Beams & Legs

1. Ensure your leg beams are horizontally level



2. Vertically level the legs as you are tightening the leg bolts



3. Horizontally level the two leg beams. You may use the main beam to span between the two legs



4. Keep the legs vertically leveled as you are tightening the cross cables, later in the installation process.

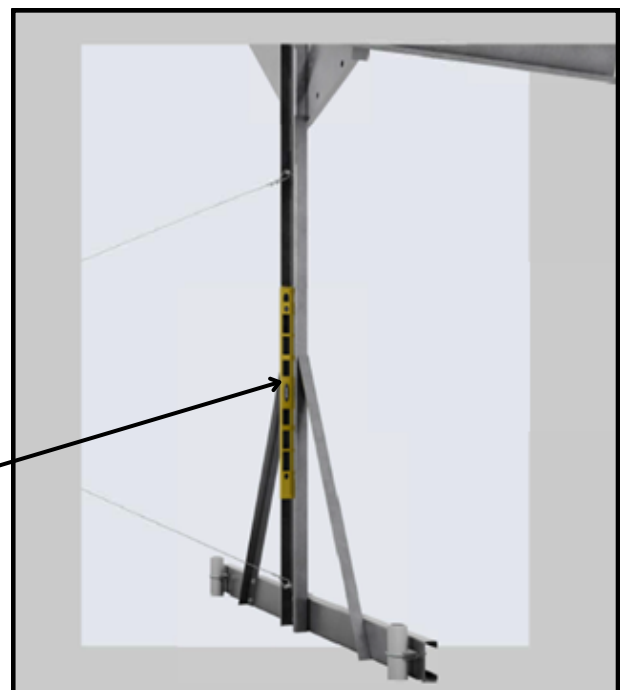

Pivot Plates

Step 3:

Method 1—Attach PRIOR to Erecting Vertical Leg Beams

The pivot plate should be on the outside of each leg. The plate needs to be able to pivot easily around the top bolt, so do not tighten the bolts too much yet.

Move the pivot plate to the “Summer Position” by rotating the plate until the top flange is at a 20° angle. Insert a bolt through the holes in the plate and leg that align in position, with a nut on the bolt but not tightened.

You will be changing the tilt at various steps.

Larger washer on each side. Lock washer on nut side.

Method 2—Attach AFTER Attaching Vertical Leg Beams

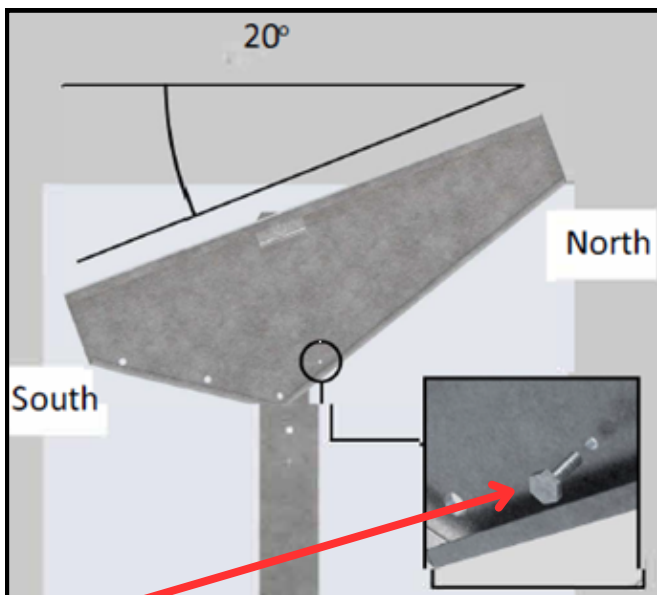

IMPORTANT: Ensure safety bolt is inserted before moving ahead with installation steps.

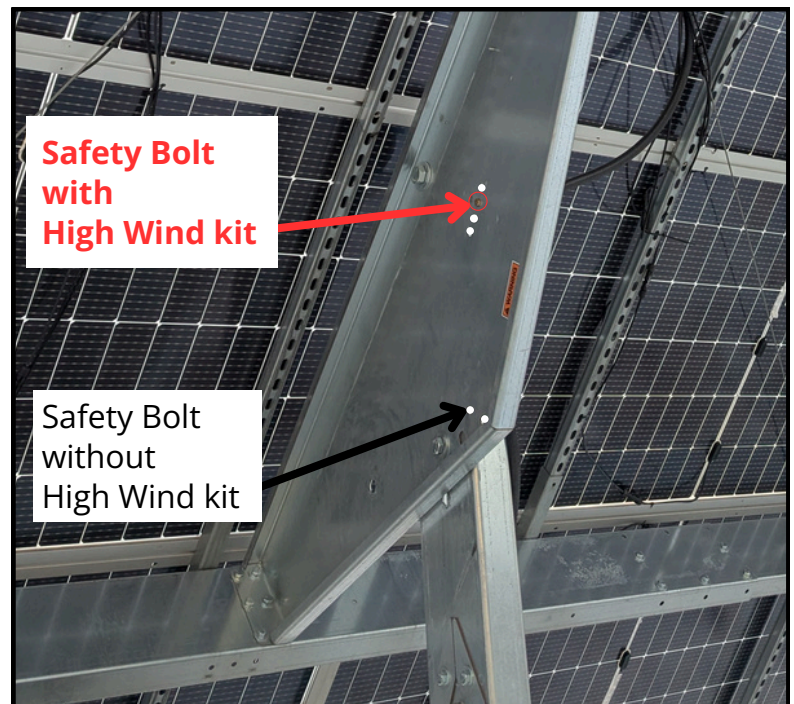
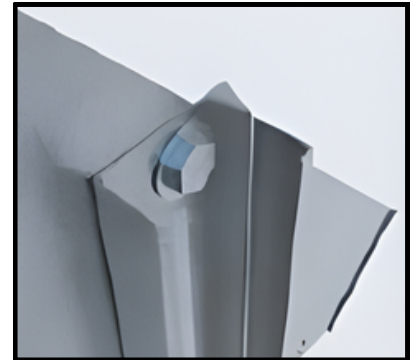
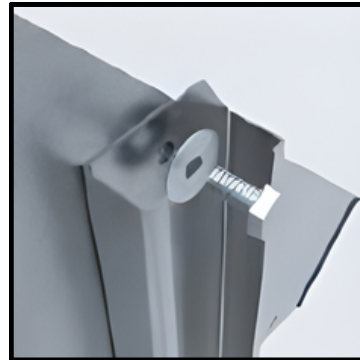

Insert a 1/2" bolt here facing inward to stop against the leg beam if over-tilted during installation

Leg Beams

Step 4:

Attach the main legs to the base beams. The angled cut at the top of the leg should be to the south.

Do not tighten the serrated bolts past snug until the angle braces (next step) have had all fasteners loosely installed.



Step 5:

Use a level to make sure legs are vertical.

Then tighten all fasteners on the legs and angle braces.

Note: Tighten all structural bolts by “Turn of the Nut” method: One-third turn past snug (mating members tight together).

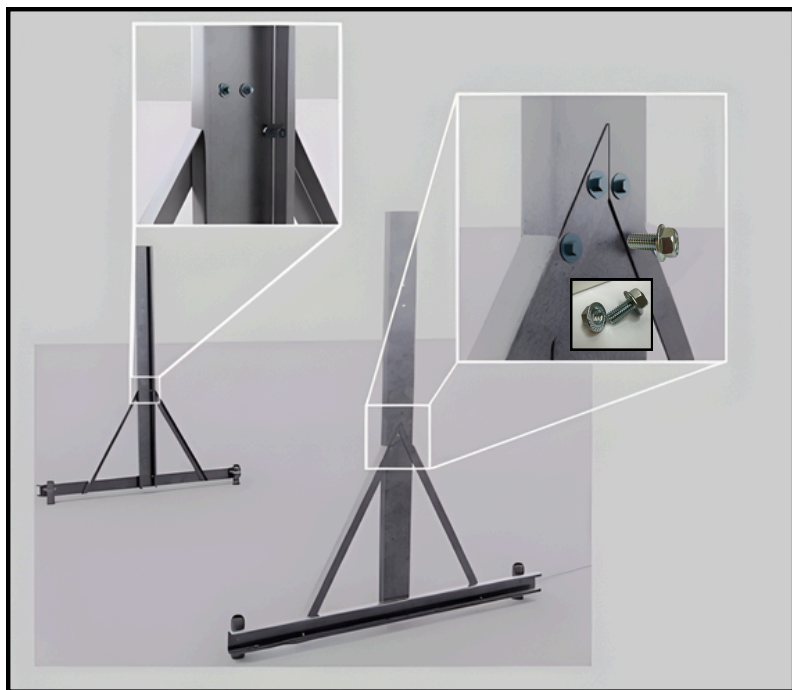

Main Beams

Step 6:

The SunRanger racking has a three-part beam, which will have a center splice and two outer beams.



Loosely install all serrated bolts and nuts. **Tighten the top 3 bolts first**, then tighten remainder.

Note: While beams are on the ground, mark the purlin and support cable holes with a marker on the upper and lower beams. Support cable locations are different on the upper and lower beams, see page 17 for locations.

Cross Cables

Step 7:

Prior to installing main beams, attach cross cables to the legs provide lateral support. The cross cables come pre-assembled and are attached using a nut and washer on either side of the leg beam. **Do not** tighten I-bolts past snug **until after step 9**.

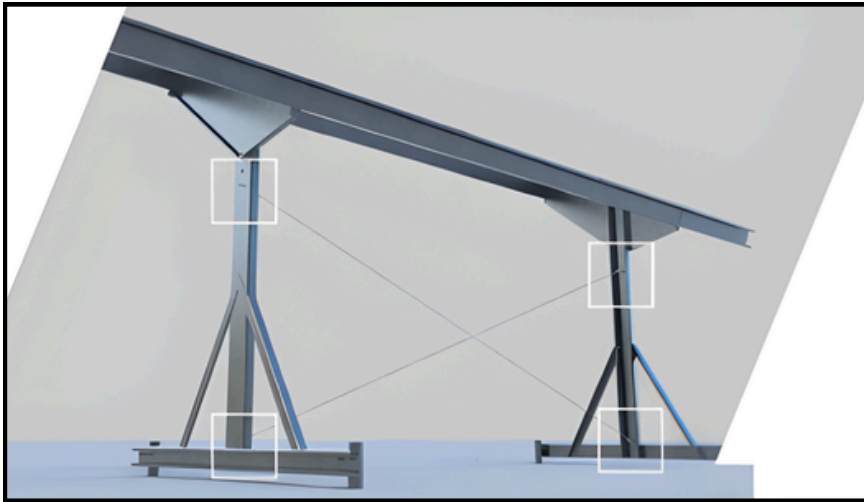

You may have a complete cable assembly where the cable clamps mentioned below will not be necessary.

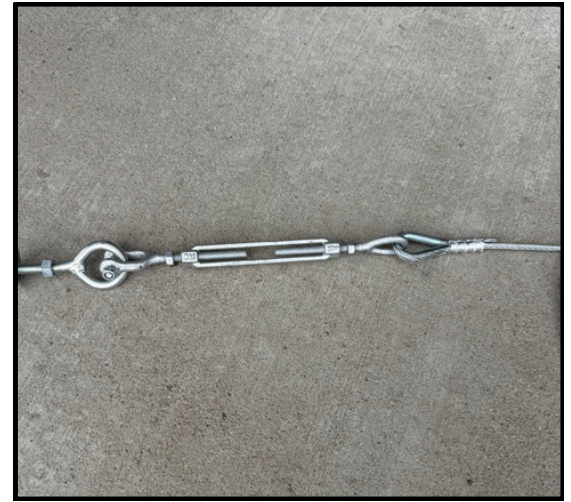

Tighten the turnbuckle to snug tightness.



IMPORTANT! The cable clamp will be installed at the center of the cable-crossing **after solar module installation is completed**.

Support Cables

Step 8:

Install the main beams to the pivot plates. Ensure that the beam flange with the installed serrated bolts is facing upwards on both beams.



Install one fastener initially, then lift the other end and install all remaining fasteners. **Do not tighten fasteners until both beams are in place.** Once all fasteners are in place, you may finish tightening all fasteners.

Step 9:

Attach support cable to the main beams. You will have two shorter cables, which will be attached on the outer connection points on the main beams. The two longer cables will be attached on the inner connection points on the main beams. See the following page for an assembly diagram. Tighten to snug, but do not overtighten until after all panels are installed.

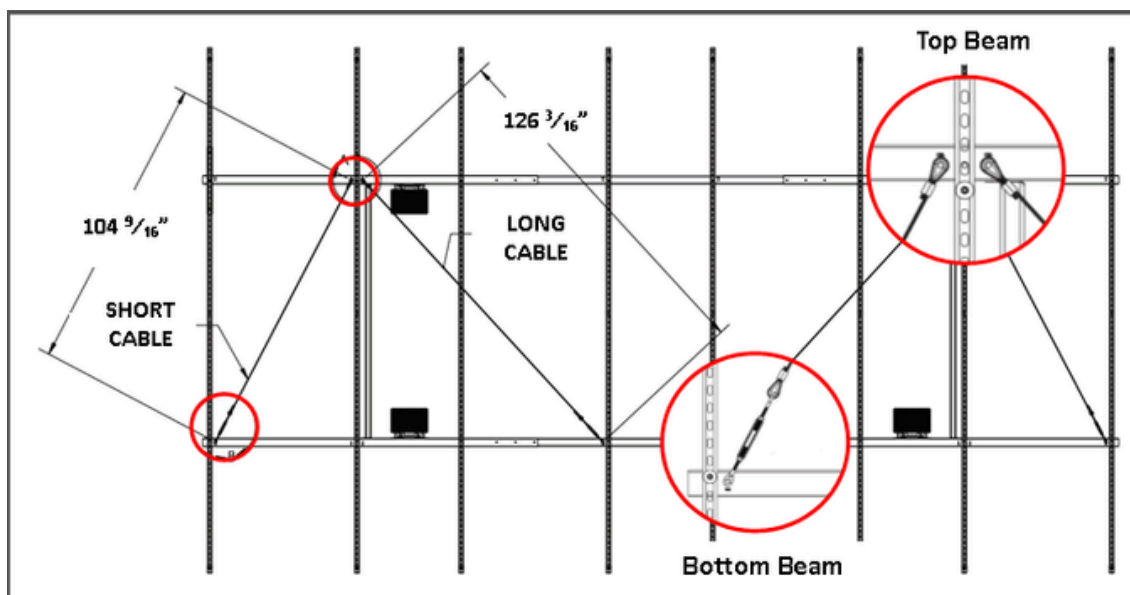

Purlin Location

Step 10:

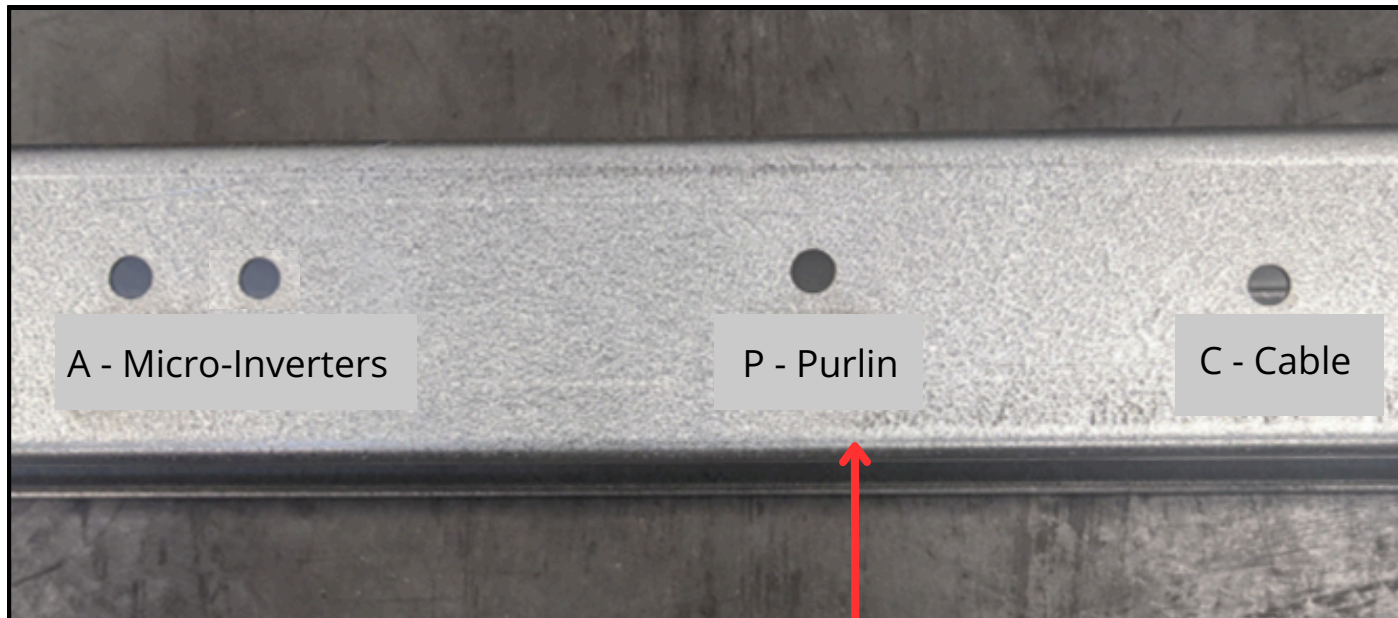

On the horizontal beam you will notice markings "A" for the micro-inverter mounting, "P" for purlins and "C" for support cables.

Purlin Location

Before installing the purlins pre-mark both ends of the purlin with the slot that is 47" (inches) or the 24th slot from the bottom ends of the purlin as well as from the top of the purlins.

The beam may sag slightly in the center of the rack so you may need to push up on the bottom beam to align the 24th slot for the bolt.

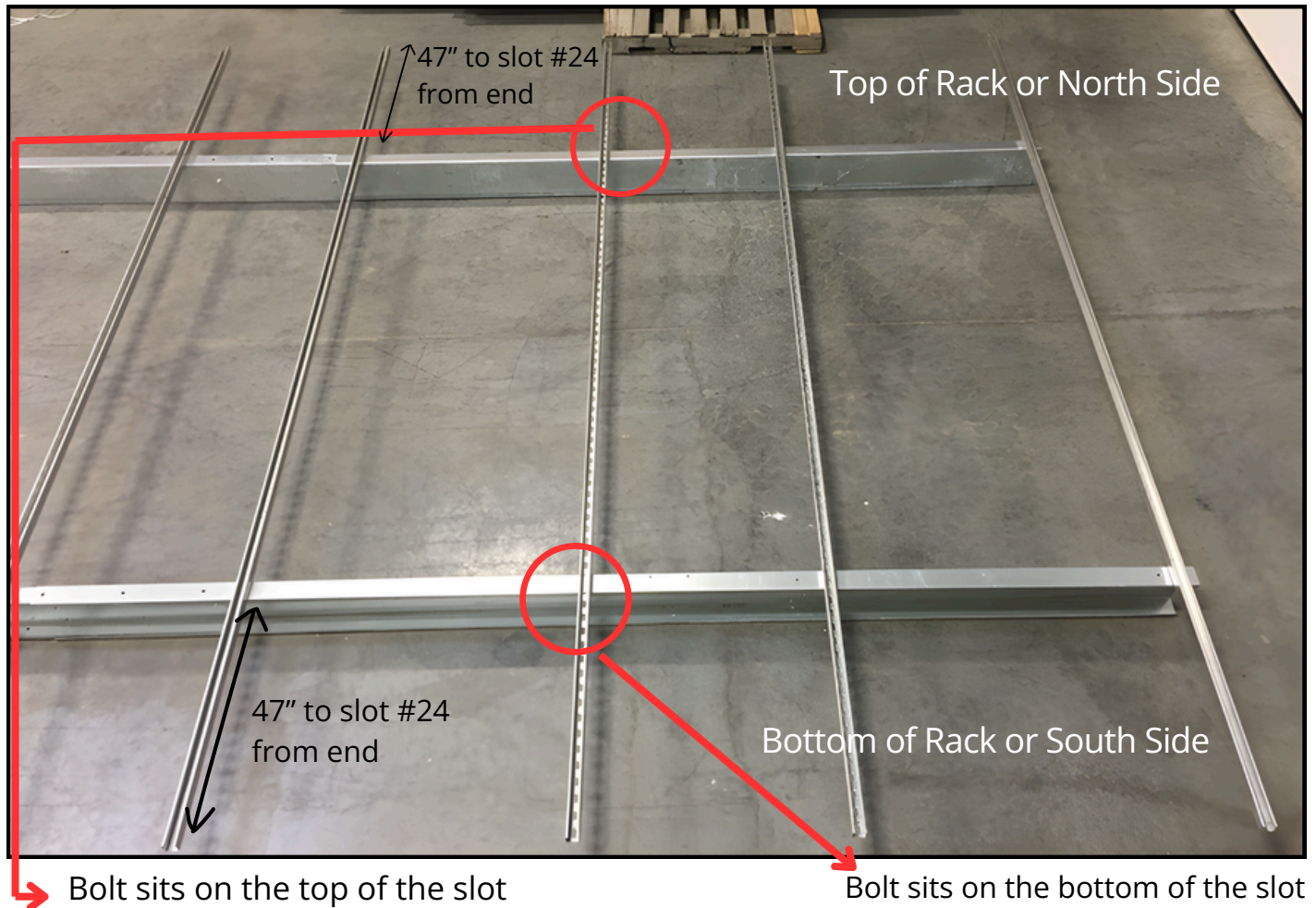

Purlin Troughs

Step 11:

Once completed, you should have eight purlins installed. If your package contains purlin troughs, follow the steps below to install.

Purlin Troughs—only required for locations with high wind and/or high snow loads.

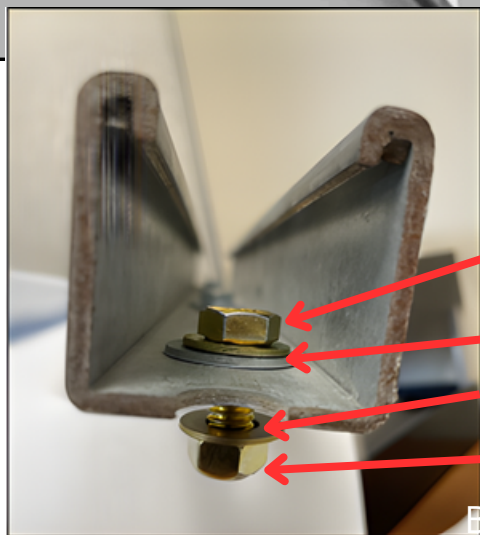
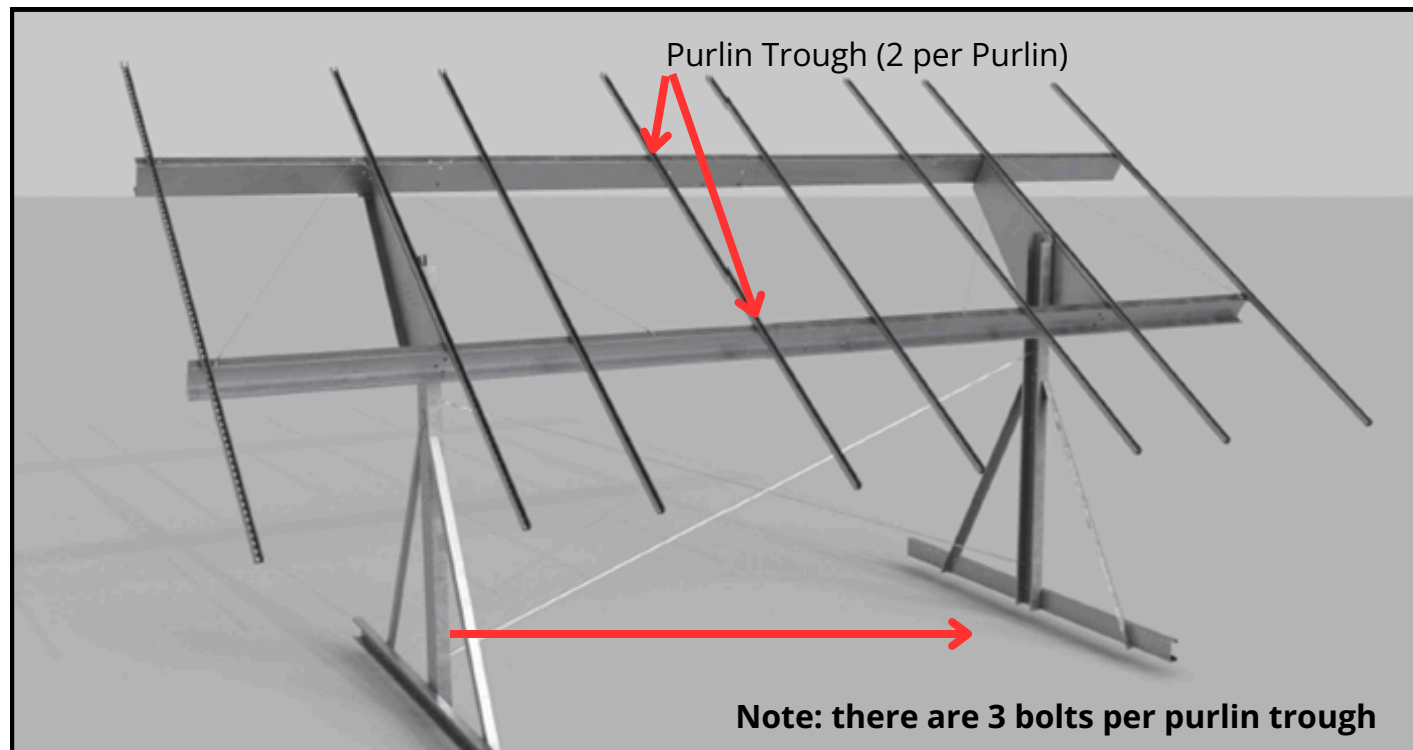

IMPORTANT:
Purlin to Beam Bolt

- Nut
- Double Washer
- Single Washer
- Nut

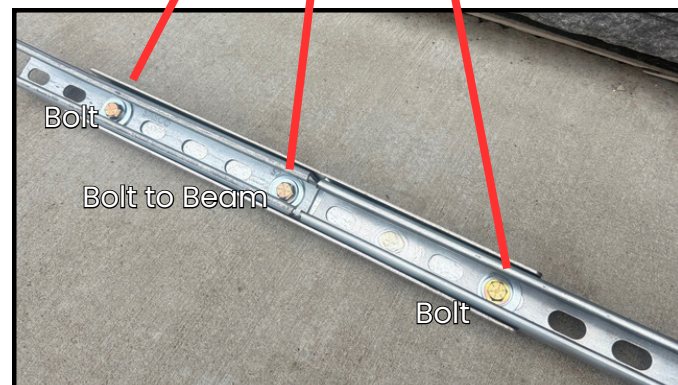
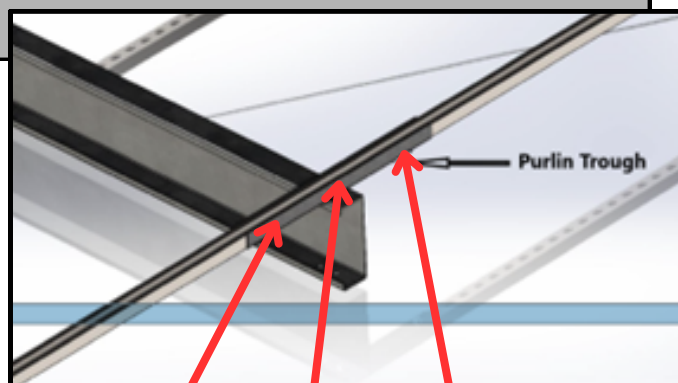

Step 12:

Install four micro-inverters.
Refer to "Micro-inverter Placement" on the following page.

Micro-inverter Placement

IMPORTANT! Remove the bar code sticker from each micro-inverter before installing and place in the corresponding location on the Connection Map(s) found on Pg. 32

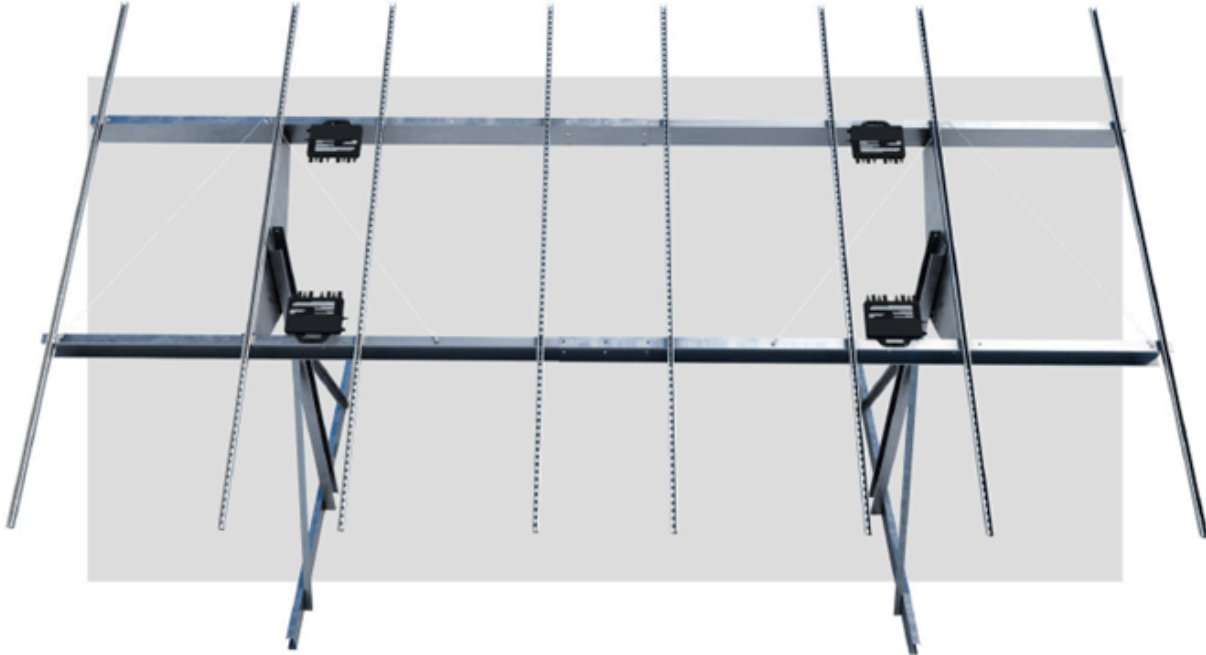

- Place micro-inverter midway between the two purlins where the 2 pre-drilled holes are.
- Bolt on with larger washer on top of the micro-inverter.
- Install micro-inverters prior to installing solar panels.
- Install the micro-inverter support pictured below under the micro-inverters at the pre-drilled holes.
- **Note: You will receive one of two bracket styles** The micro-inverter-mounting hole on the main beam may vary depending on the micro-inverter used. You may need to drill new holes for mounting the micro-inverter support bracket.



Solar Module Installation (Option 1)

Step 13:

Install the bottom (south) Z-clips to the lower end of the purlins.

The fender washer will be on the bottom of the purlin with the Z-clip on the top.

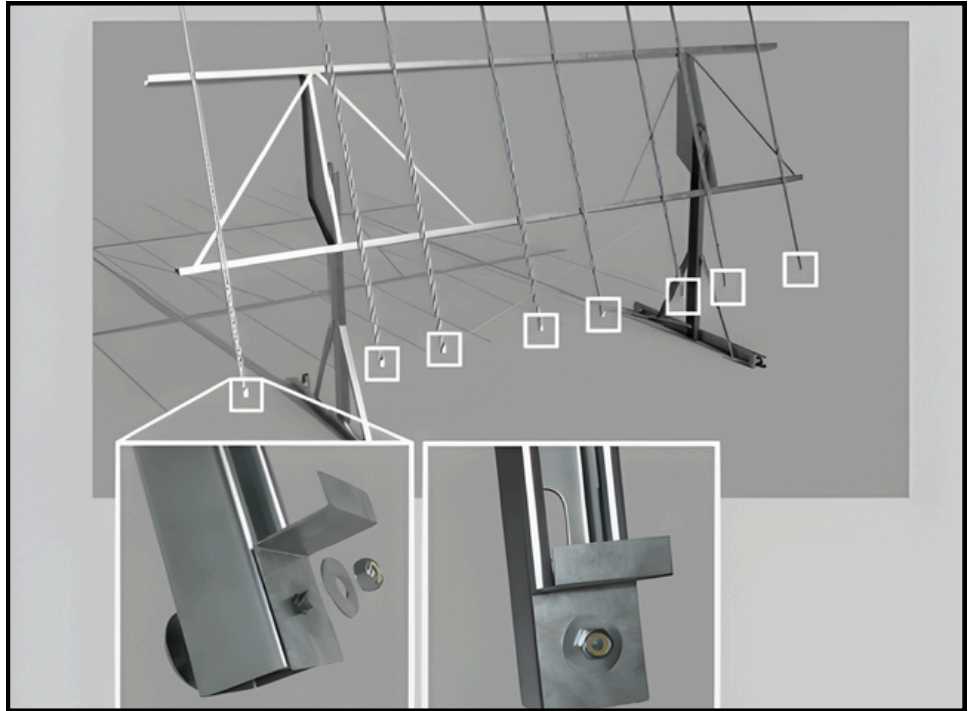

Step 14:

Insert the first module into place at the end of the rack.

The panel should be in landscape position. Final adjustments will be required once the first row of panels is completed, to center the panels.

Refer to the following page for panel bolting/bonding washer details.

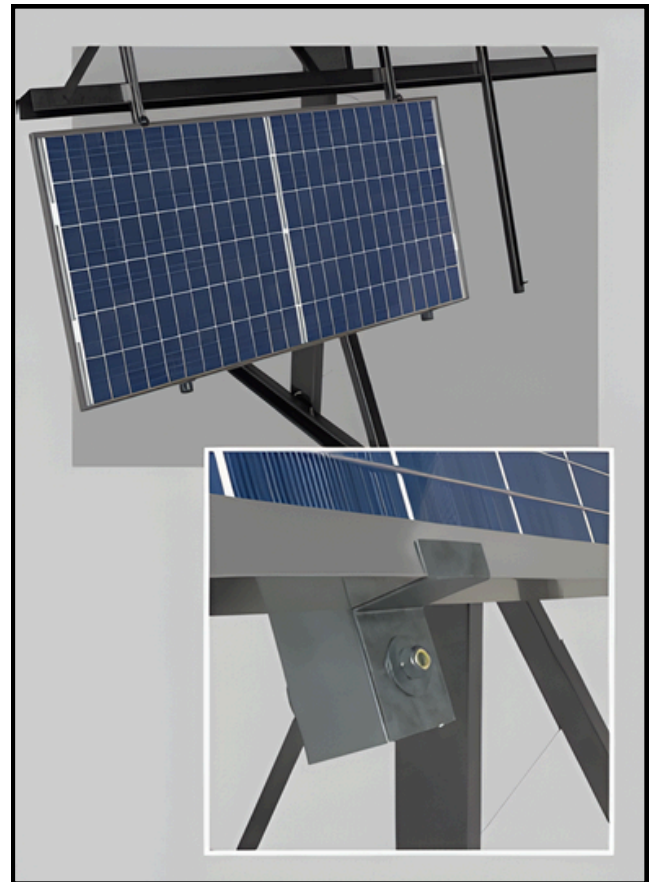
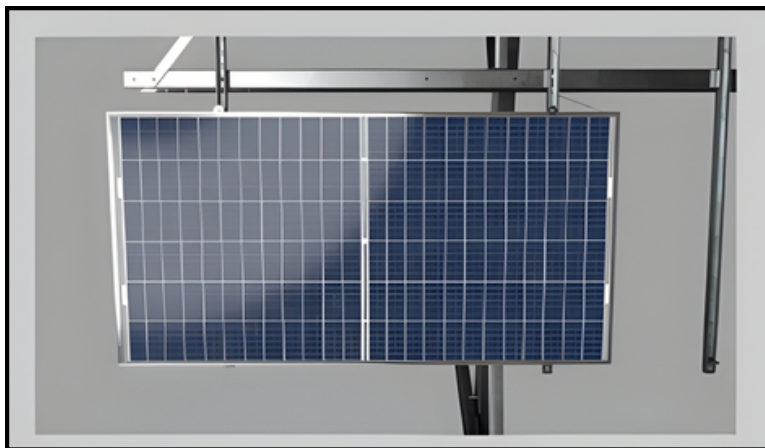

Solar Module Installation (Option 2)

Top z-clips

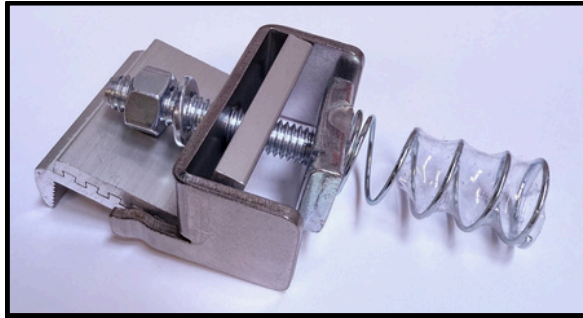

IMPORTANT:

If you have **adjustable z-clips** make sure the z-clip is set to the thickness of the panel. If it does not match the panel thickness, you may crack the panel upon tightening. Clip should just be snug after tightening.

Bottom z-clips with bolt

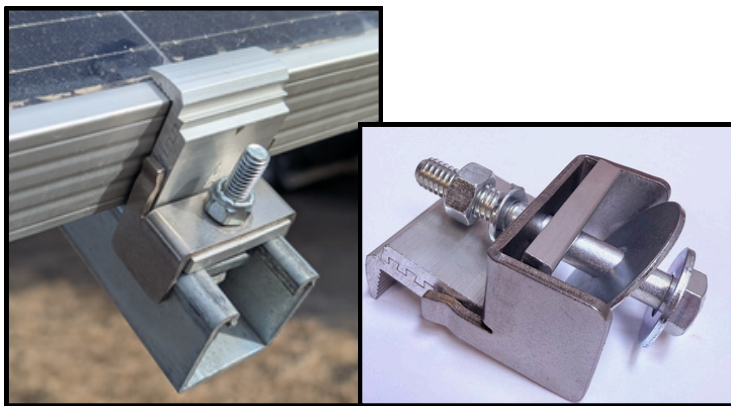

Depending on the solar panel used you may wish to trim excess purlin length on top and or bottom, but excess purlin length may be left as is..

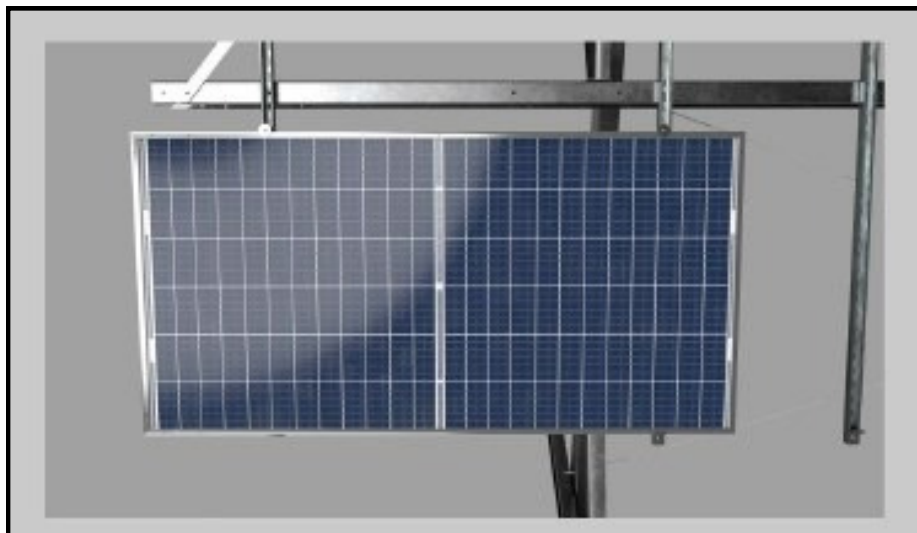

Panel Bolting Detail

Step 15:

IMPORTANT! Bonding washers are to be used one time only. If any modules are removed and replaced, new bonding washers must be installed.

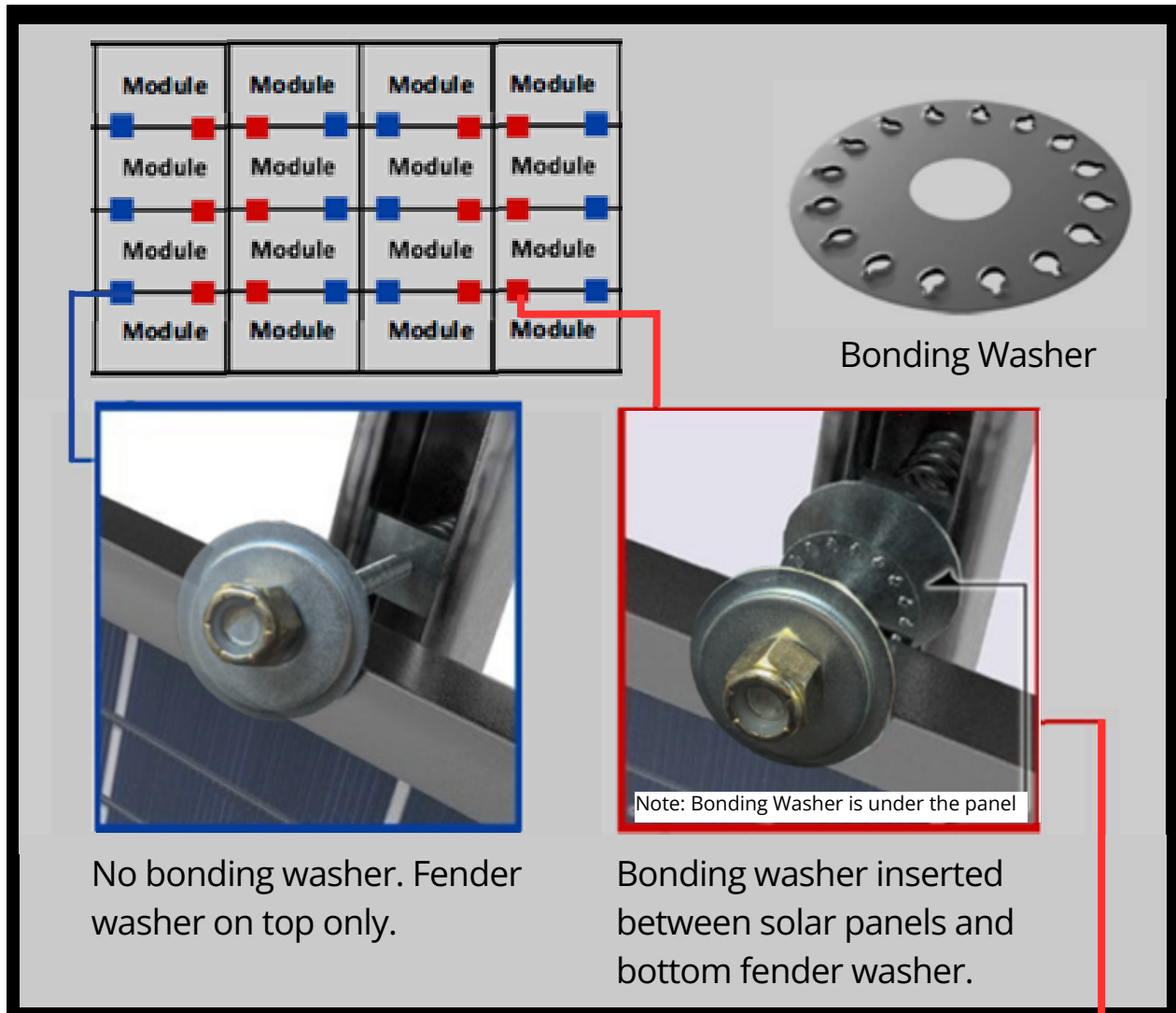

- Spring-bolts with 3/8" x 2-1/2" studs, placed into the purlins
- A 3/8" fender washer
- An AKS bonding washer
- Two solar modules placed -one of either side of the protruding stud
- A fender washer placed onto the stud
- A 7/16" flat washer
- A 3/8" Nyloc nut installed and torqued to 12-15 lbs. - ft once solar panels are in position on each side of the fastener.
- **IMPORTANT:** DO NOT OVER-TIGHTEN THE PANEL NUTS. Overtightening may shatter the solar panel.

Solar Module Installation

Step 16:

Continue Installing Remaining Solar Panels:

Install the rest of the bottom row of panels. Make sure they are carefully aligned with each other along the top and bottom before moving on to the next row.

If they are misaligned, loosen and adjust the Z-clips until the panels are aligned, then re-tighten the Z-clip fasteners. Also, check to see if the amount of the panel overhanging past the outside purlins is approximately equal and adjust if necessary.

After any adjustments to the bottom row alignment are complete, install remaining panels row by row.

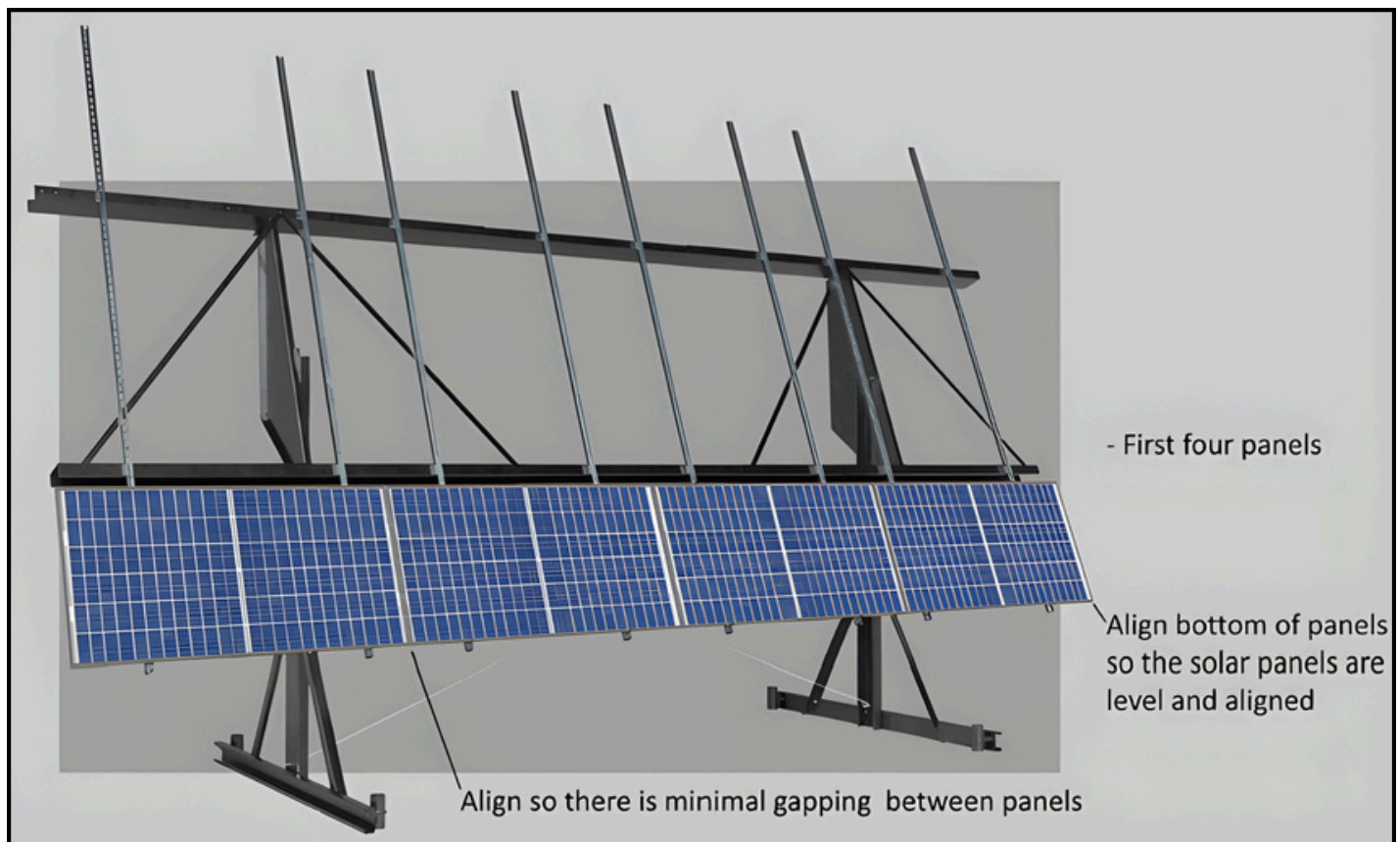

Solar Module Installation

Spring Clip Installation Note:

IMPORTANT! When installing the solar panels on top of the spring clip bolt, sliding the panels along the spring clip bolt may cause the bolt to turn and unlock from the purlin below.

After installing the washer and nut on the spring clip bolt, **check that the length of the bolt is consistent with the others. Pull on the solar panel to be sure the spring clip bolt is locked in place.**

The solar panel will lift off if the spring clip bolt is not seated correctly.



If the clip has popped out of the purlin, you will be able to tell as the spring clip bolt will be protruding out further.



The clip should remain within the trench of the purlin.

Solar Module Installation

Step 17:

There are a number of ways to complete the solar panel installation. We have illustrated 3 methods on the next several pages. Determine which method you are the most comfortable with and, most importantly, please consider your safety as well as the safety of others while installing.

Solar Module Installations: Method 1

Install the rest of the bottom row of panels. Make sure they're perfectly aligned with each other along the top and bottom before moving on to the next row.

If they're misaligned, loosen the Z-clips and adjust the Z-clips until the panels are in place.

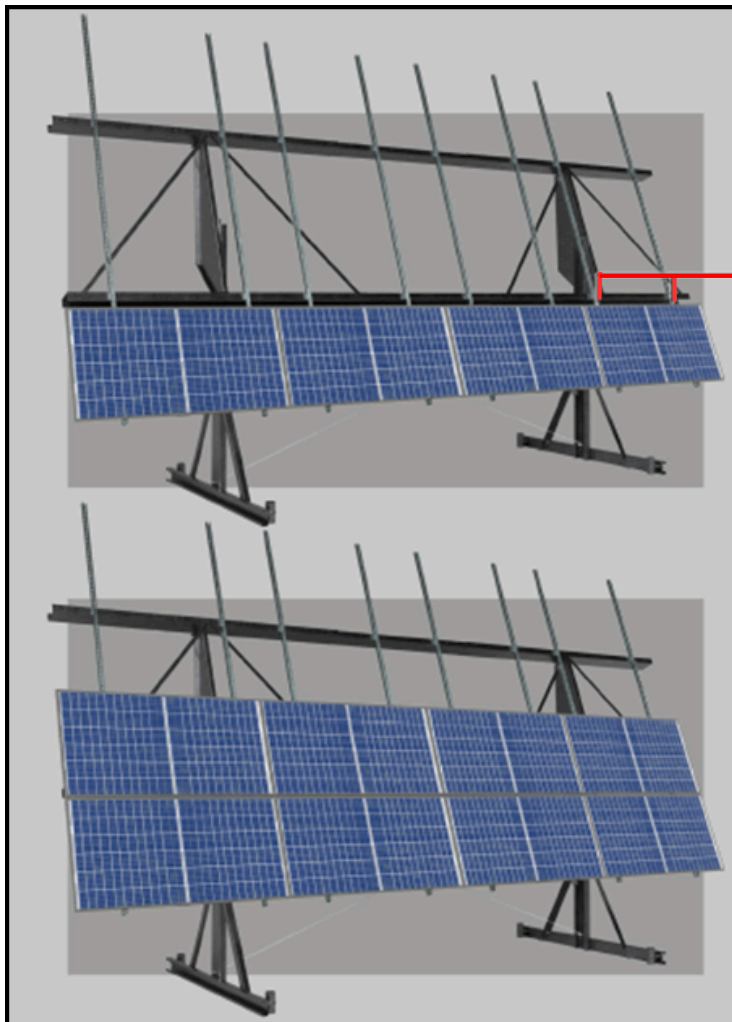

Refer to page 22 for location and type of spring bolts and washers.

Install spring bolts on all purlins to hold down solar panels.

-First four panels

-Next row of panels

Solar Module Installation

Method 1 Continued:

Once the second row of panels is installed, use straps and pullies to pull the system into the "Summer Position". It will be too heavy to pivot by hand at this stage in the installation process. Once in the Summer position, secure it with a bolt before continuing with the module installation.

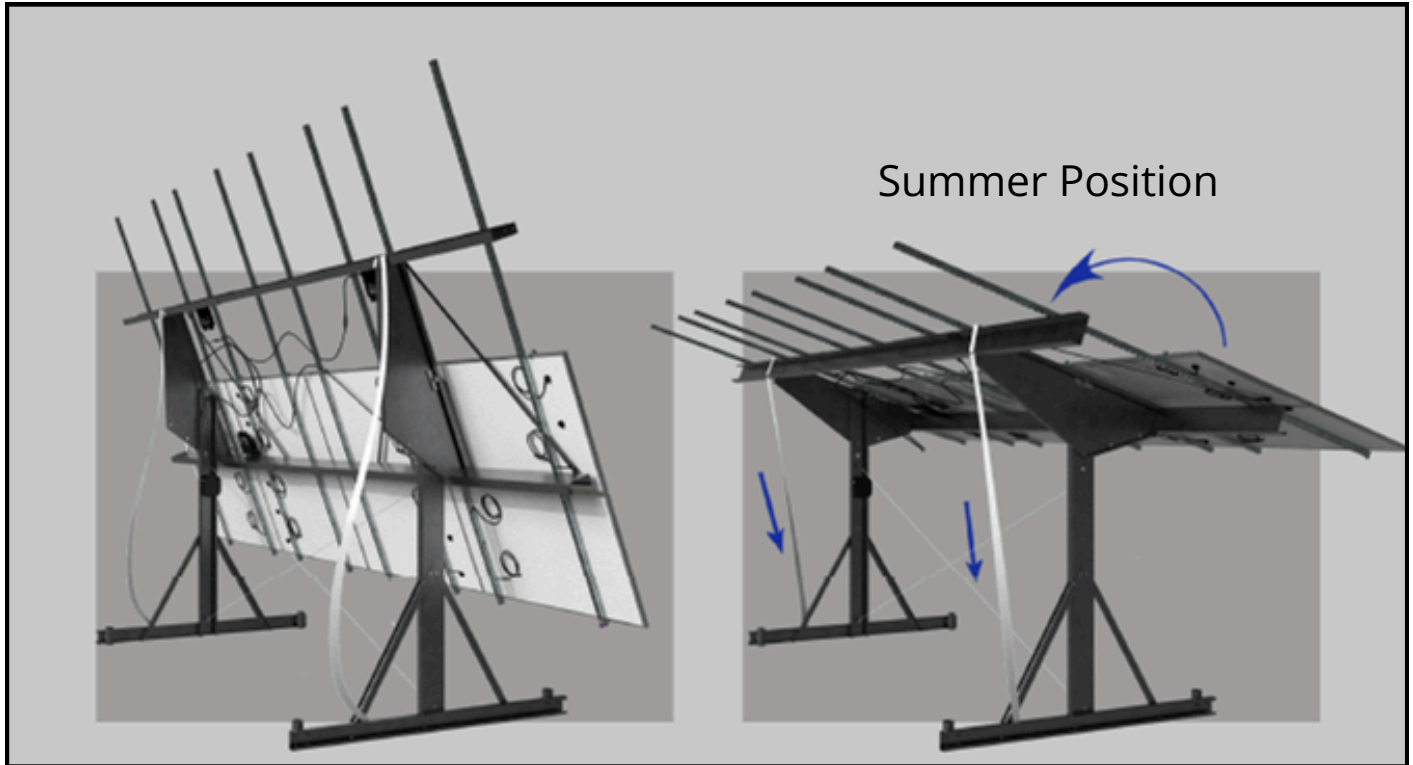

From this summer position you will need ladders to install the last two rows of panels.

REMINDER! The cable clamp will be installed at the center of the cable-crossing **after solar module installation is completed.**

Solar Module Installation

Sollar Module Installation Method 2:

Install all solar panels with the racking in the "Summer Position".



Sollar Module Installation Method 3:

If you have access to a manlift, it's best to keep the rack in the winter position as you install the panels. Install the solar panels row by row.

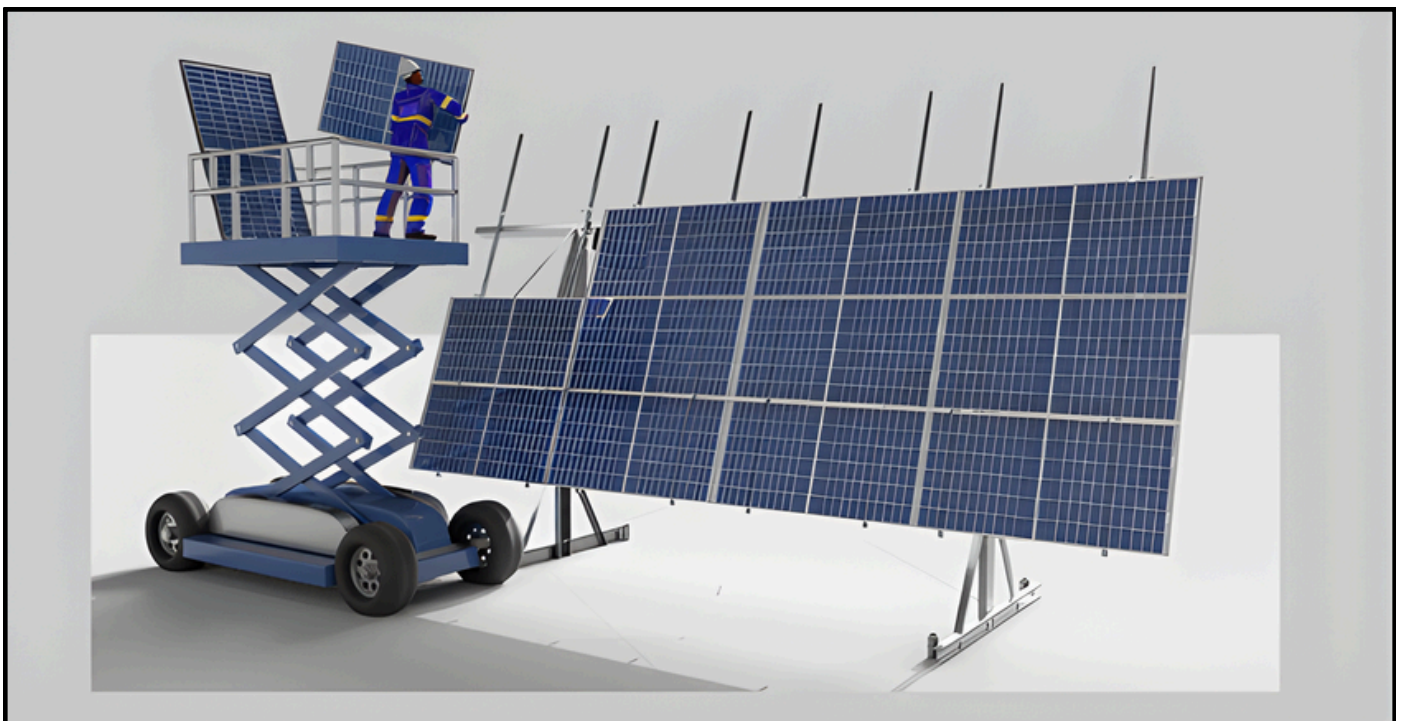

Solar Module Installation

Step 18:

Install the top (north) Z-clips (with spring nuts hardware) on the top row. Ensure the grooves in the spring nuts remain engaged with the lip edges inside the purlins while tightening. If the end of the purlin is slightly deformed the spring nut may not remain engaged through the tightening.

Note: Refer to Option #2 on page 21 if using the adjustable z-clips

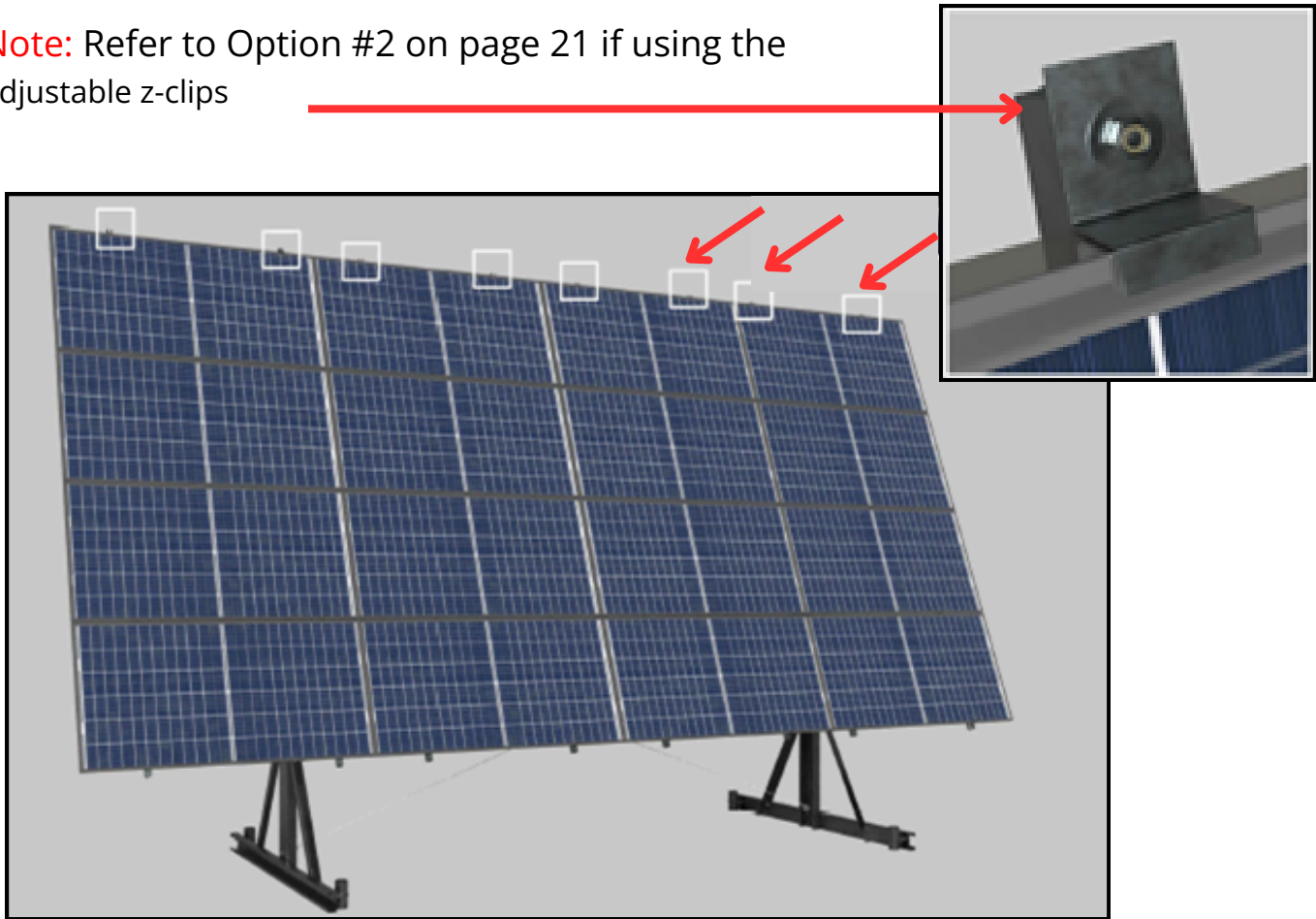

When rack and panels are complete, move to the “Summer Position” and tighten pivot plate bolts.

The top pivot plate bolt should be snug, but not too tight to restrict the movement of the rack when changing the position. After you establish the correct pivot plate position and bolt tightness, “LOCTITE” may be used on the top pivot plate bolt.

IMPORTANT! Do not leave racking units with solar panels partially installed in windy conditions. Move to the “Summer Position” if partially completed.

Micro-inverter Connection

1. Each micro-inverter connects to 4 solar panels.
2. String the solar panel cables between the purlins and the solar panels where possible.
3. Connect the 2 cables from each solar panel side by side onto the micro-inverter (image).
4. Press firmly to make the proper connection, you will hear a “click”.
5. Arrange the cables together and use zip ties to secure the cables.

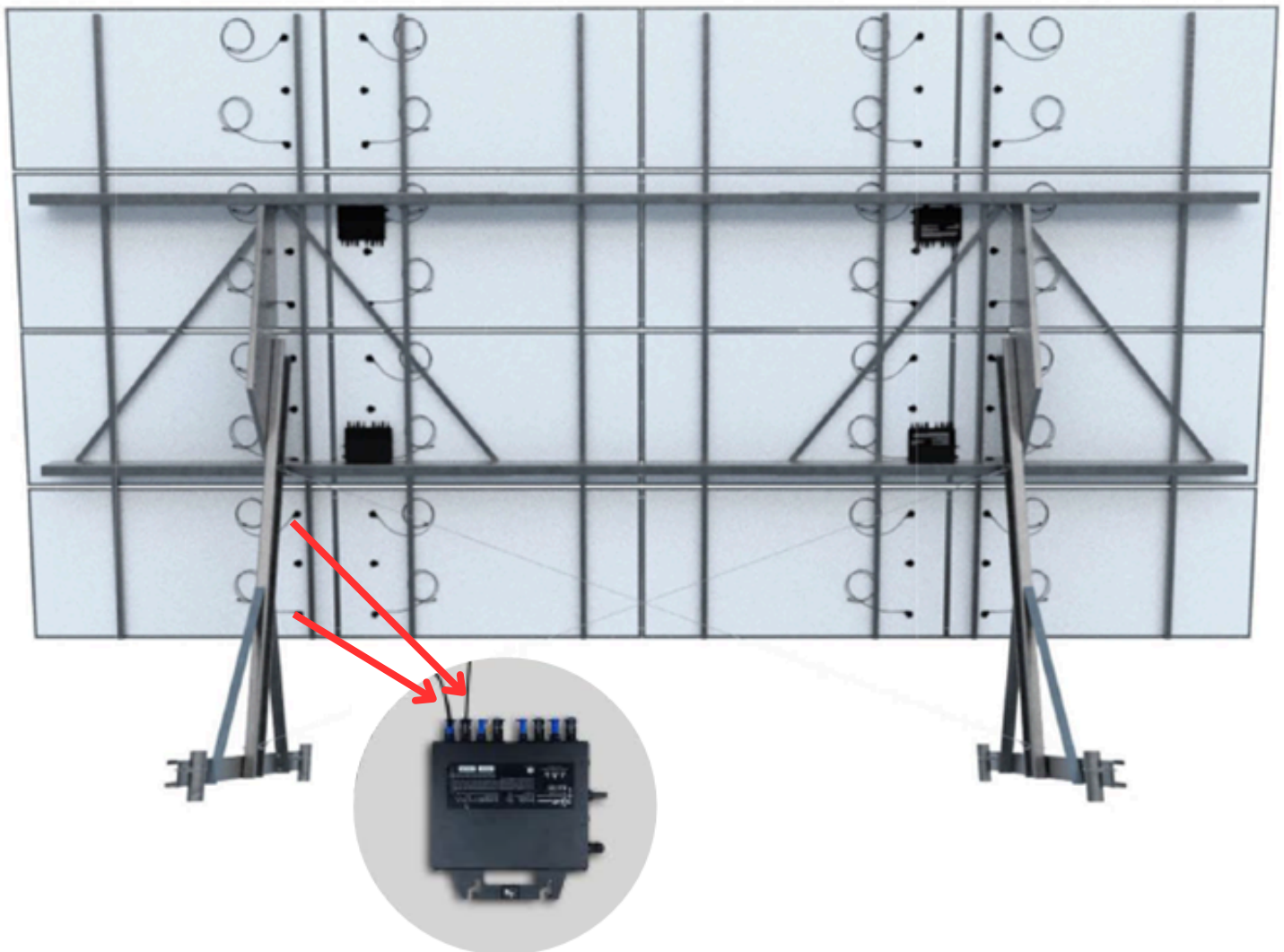

IMPORTANT! Remove the serial number stickers from each micro-inverter before installing, then place in the corresponding spot on your 'Micro-inverter Connection Map' found on page 32. This will be used to set-up your system for data monitoring.

High Wind Support

High Wind kit Consists of 3 Additional Components

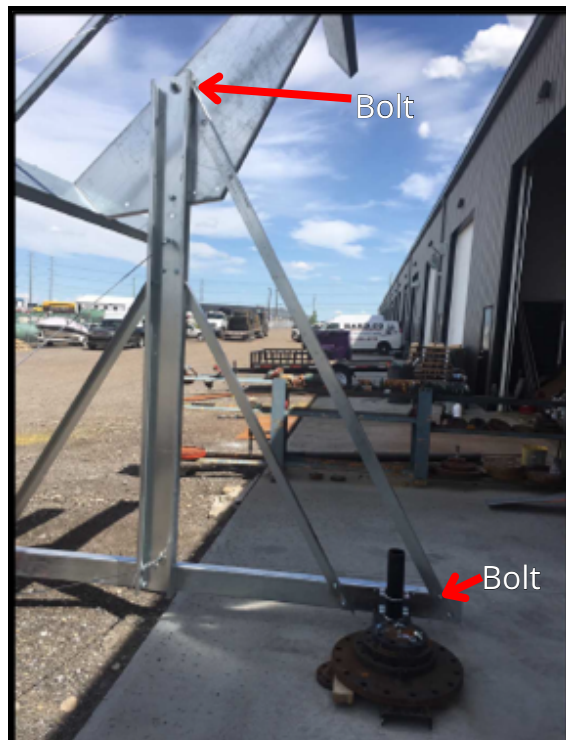
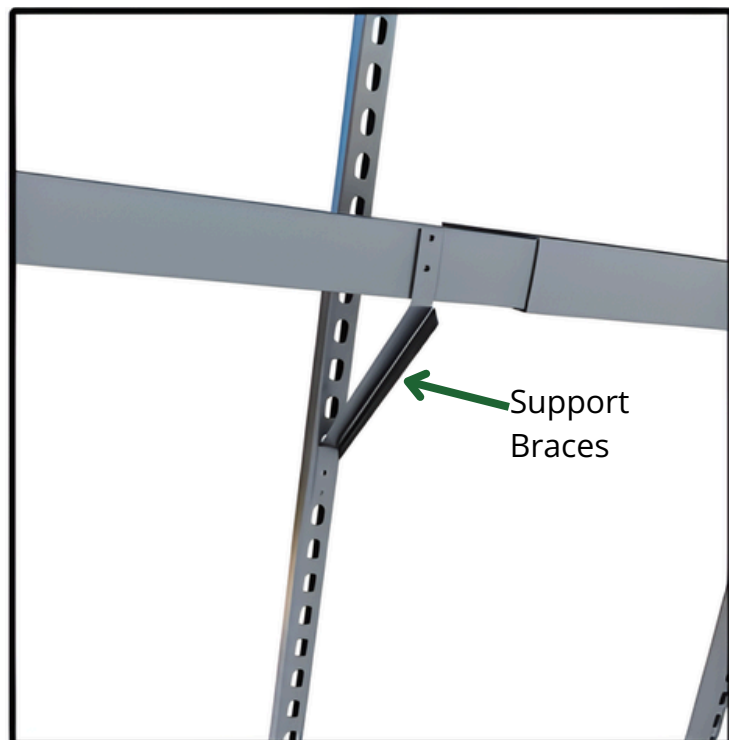
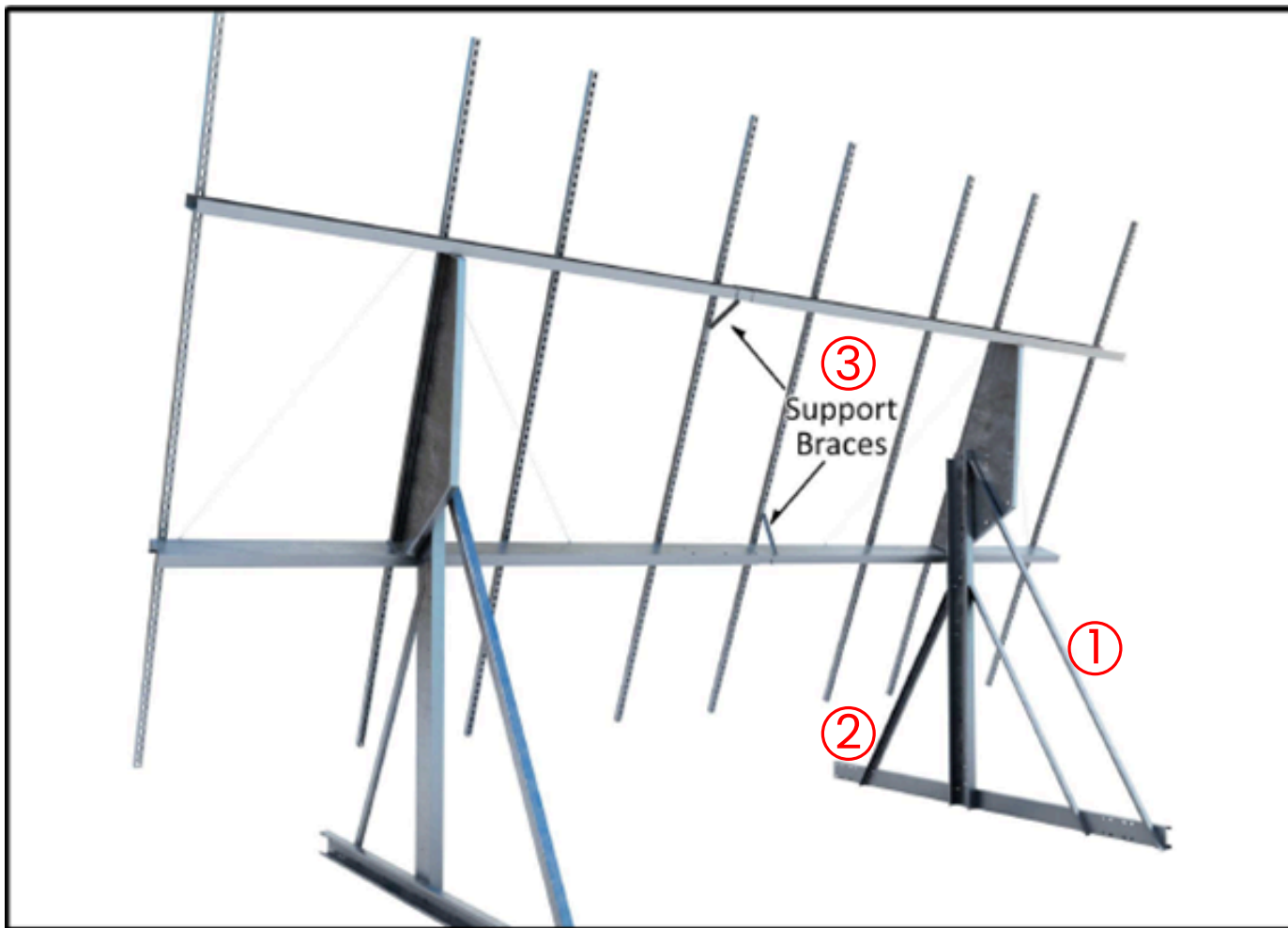

High Wind Support

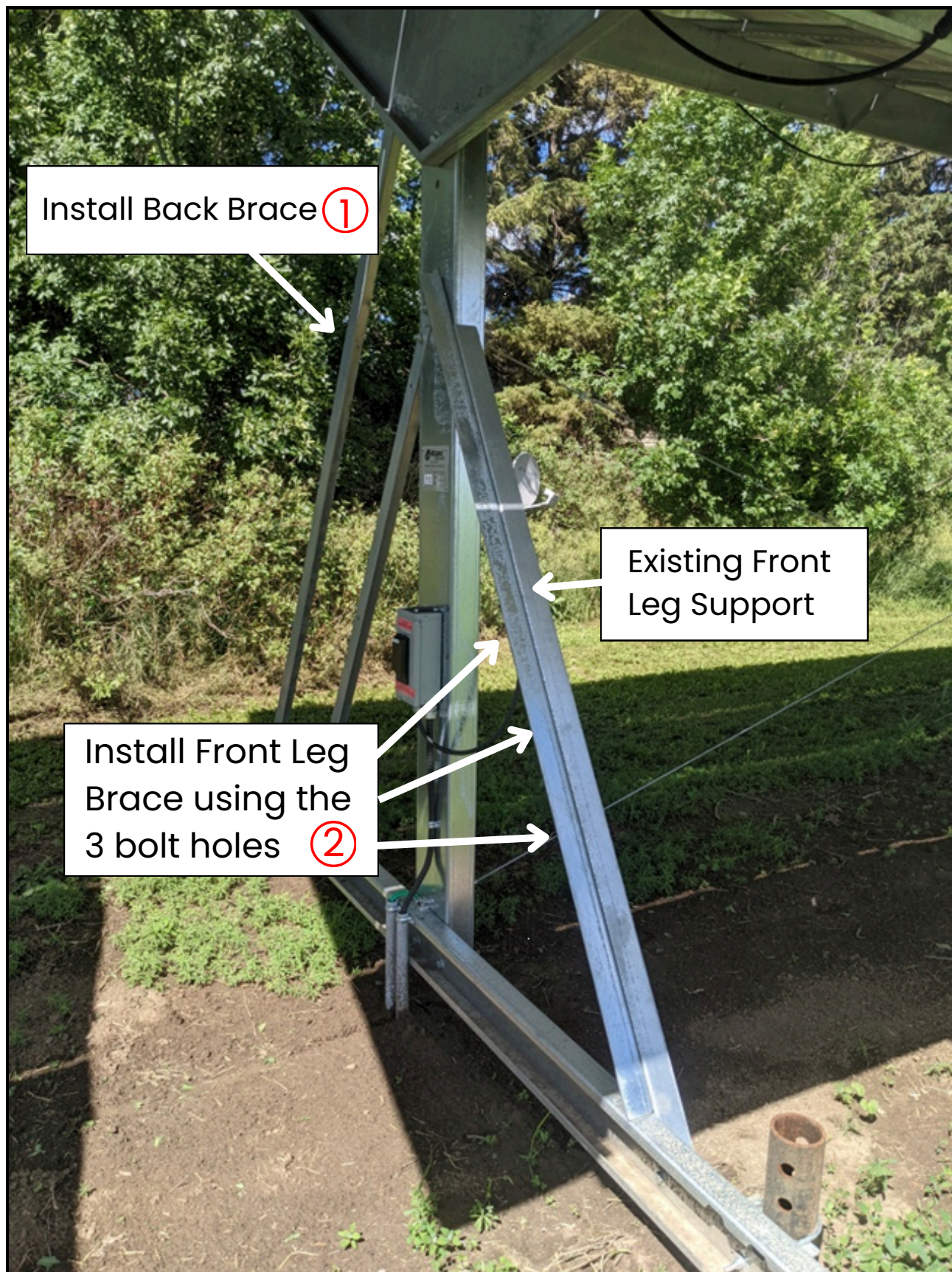

Micro-inverter Connection

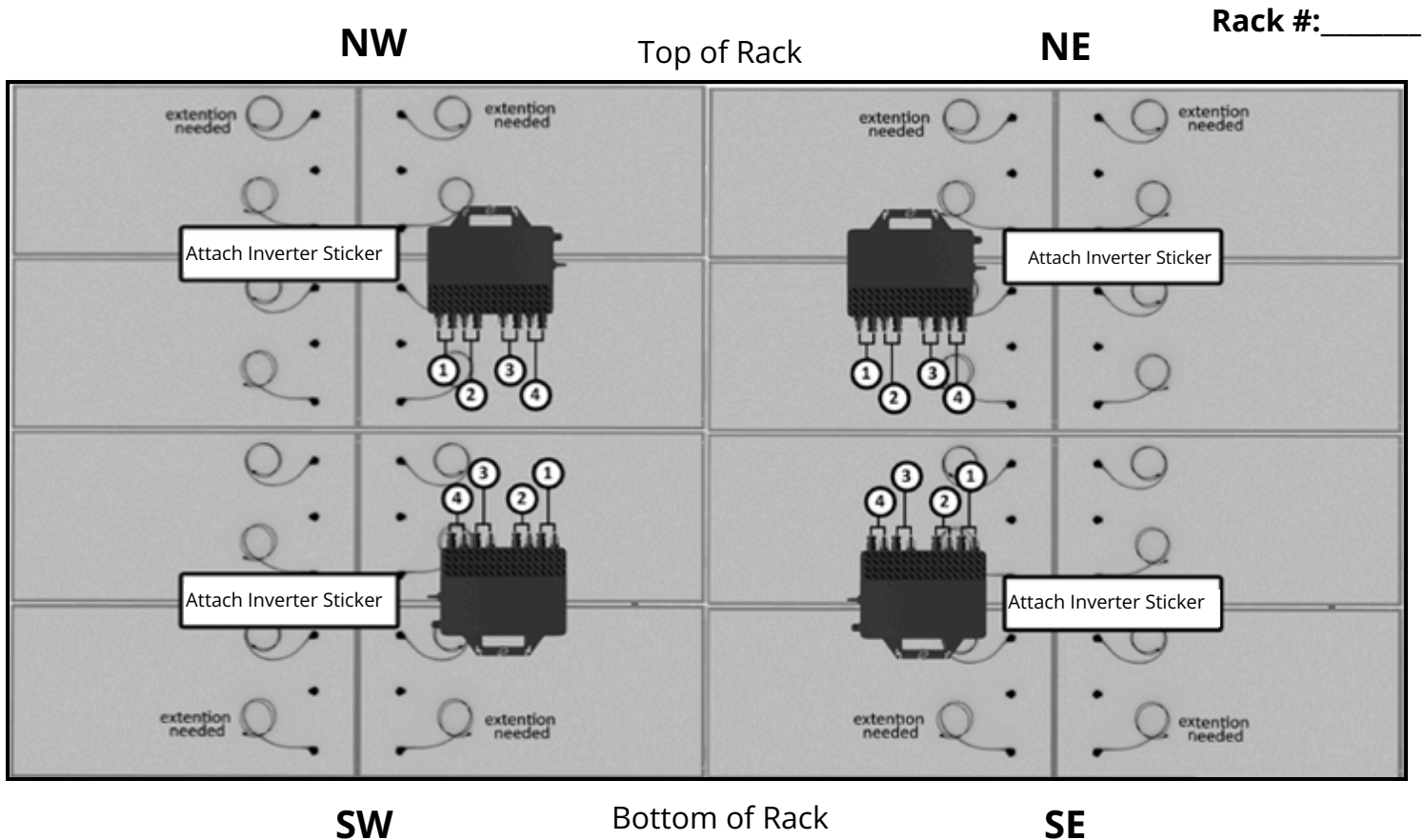

- Remove each bar code sticker from the micro-inverter and place in corresponding location on the connection map.
- Please send a copy to Azgard Solar and keep a copy for your own records.
- **This information will be used to set-up your account for system monitoring.**
- If you have multiple racks, use one connection map per racking unit. Number the racks in the top right-hand corner to ensure the layout in your system monitoring displays accurately.

Remove the sticker prior to installing each inverter, as it will not be visible or easily accessible after the inverter is installed

Micro-inverter Connection

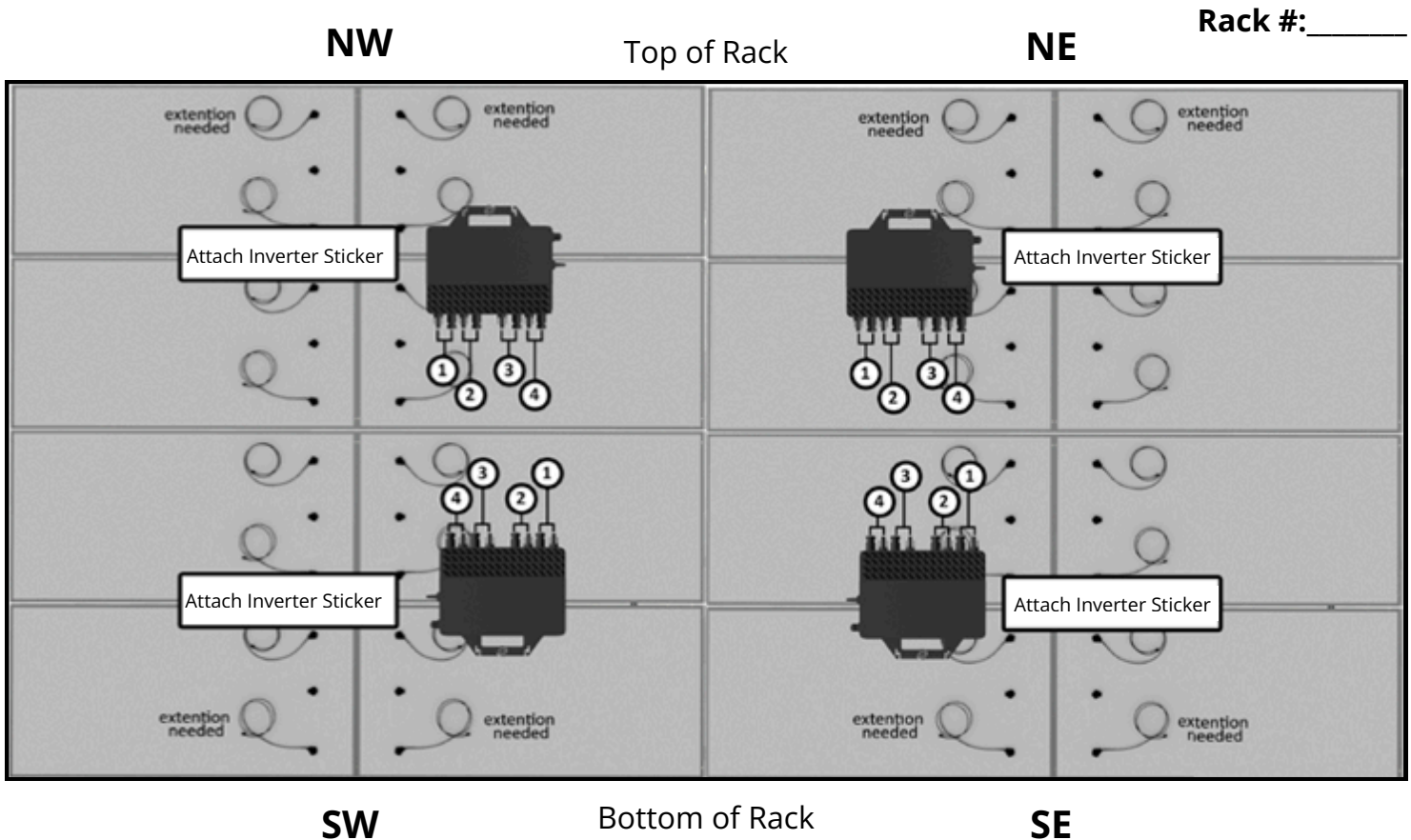

- Remove each bar code sticker from the micro-inverter and place in corresponding location on the connection map.
- Please send a copy to Azgard Solar and keep a copy for your own records.
- **This information will be used to set-up your account for system monitoring.**
- If you have multiple racks, use one connection map per racking unit. Number the racks in the top right-hand corner to ensure the layout in your system monitoring displays accurately.

Remove the sticker prior to installing each inverter, as it will not be visible or easily accessible after the inverter is installed

Post-Installation Checklist

Upon completion of your solar system installation, Azgard will require the following information to enable remote monitoring of your system:

- Connection map(s) with micro-inverter serial number stickers attached
- Photos of your completed system—(front and back view)

All photos/information can be sent to: npahara@azgard.com

Maximize the Value of your SunRanger® Solar System

- Sign up for the **Solar Club** through our other division, Azgard Energy inc.
 - **Get paid for your excess solar production and accelerate your system's payout.**
 - Call 403-236-5501 today to learn about our special pre-solar rate available until your system is installed, or **visit www.azgardenergy.com** to get started. It's free to join!
- Sell your Carbon Credits:
 - Visit **www.solaroffsets.ca** and click sign up, Enter your information in the form, when completing the form, under "how did you hear about us" Select My Installer and "who was your installer" **Select Azgard Solar Inc.**
- For Incorporated Businesses:
 - Consult your accountant regarding the Refundable Investment Tax Credit (ITC) and Capital Cost Allowance (CCA) to determine eligibility and **maximize available deductions.**

If you would like assistance registering with these programs or would like to learn more, please contact our office at 403-236-5501

SunRanger Seasonal Adjustment Dates

2 X Year



4 X Year

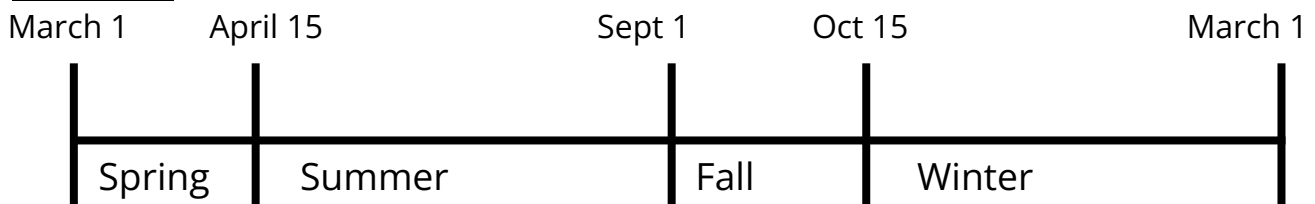

Important Note: in the event of extremely high winds or severe storms, system may be adjusted to summer position for less wind-resistance

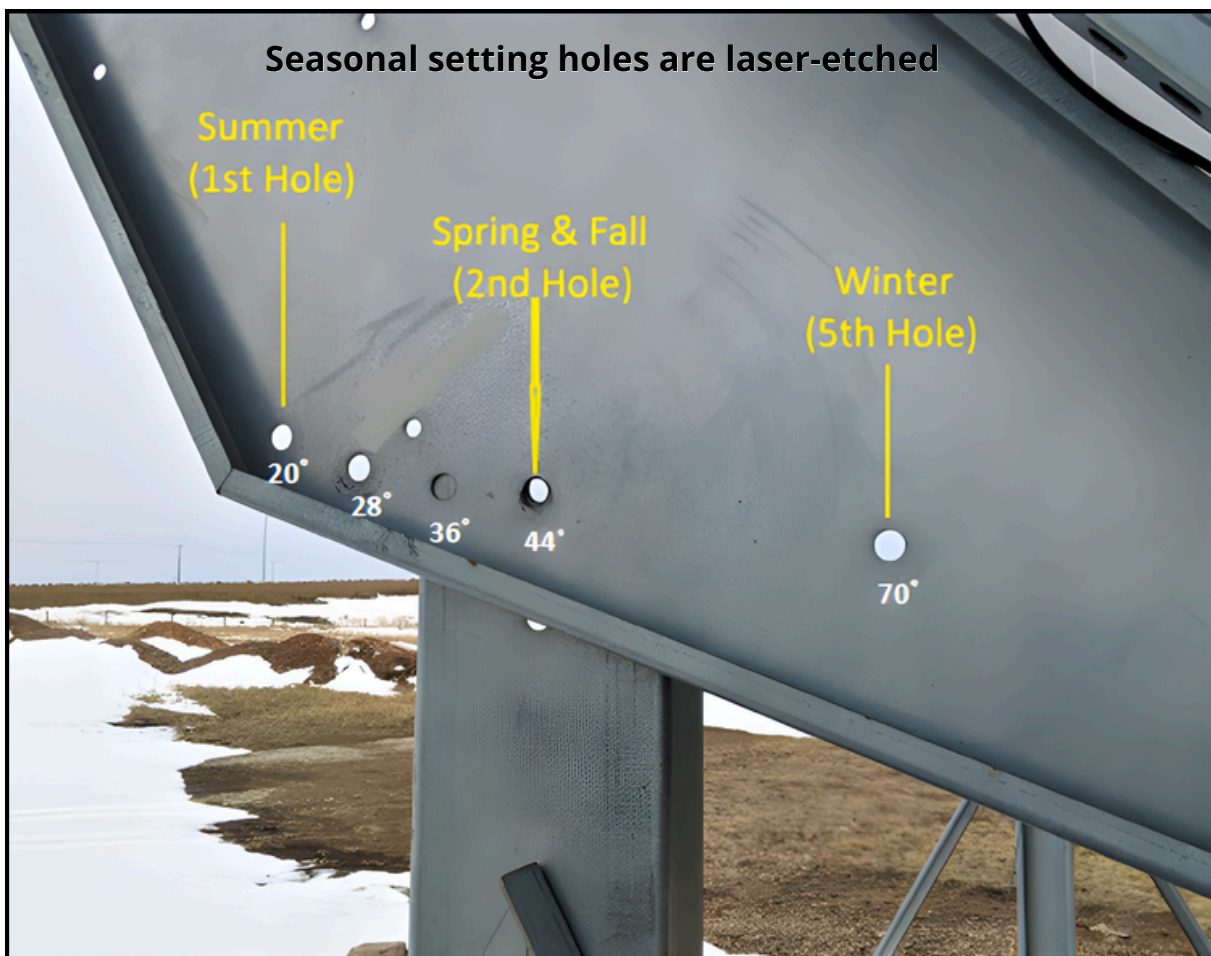

Thank you for your purchase!
If you have any questions regarding these instructions,
please contact our office.

Patrick Fulawka

Cell: (403)-815-8515

Office: (403)-236-5501

Email: pfulawka@azgard.com

Head Office Address:

Unit 2, 34 Wrangler Pl SE

Calgary, AB T1X 0L7

Email: info@azgard.com

Access step-by-step installation videos through Azgard resources:

Online: www.azgardracking.com

YouTube: SunRanger Instructional Install Video

