

SunRanger® Monopole MP-8L



www.azgard.com | Phone: 403-236-5501

Monopole 8L System Includes:

- 1 Hardware package
- 2 Pivot plates (laser etched East and West)
- Pile pivot adapter
- 2 Pile saddles
- 4 Purlins
- 8 Purlin troughs
- 2 Beams 148"

This manual contains 2 sections:

Section 1 :

- MP-8L Spec Sheet (Page 3)
- Step by Step Assembly Instructions for the primary workflow (Pages 4 -24)

Section 2 :

- Contents (Page 25)
- Field References with photo's and configuration options (Pages 26 - 31)

Last page: Contact information (Page 32)

Section 1

ASSEMBLY INSTRUCTIONS

SunRanger® Monopole ST-8L

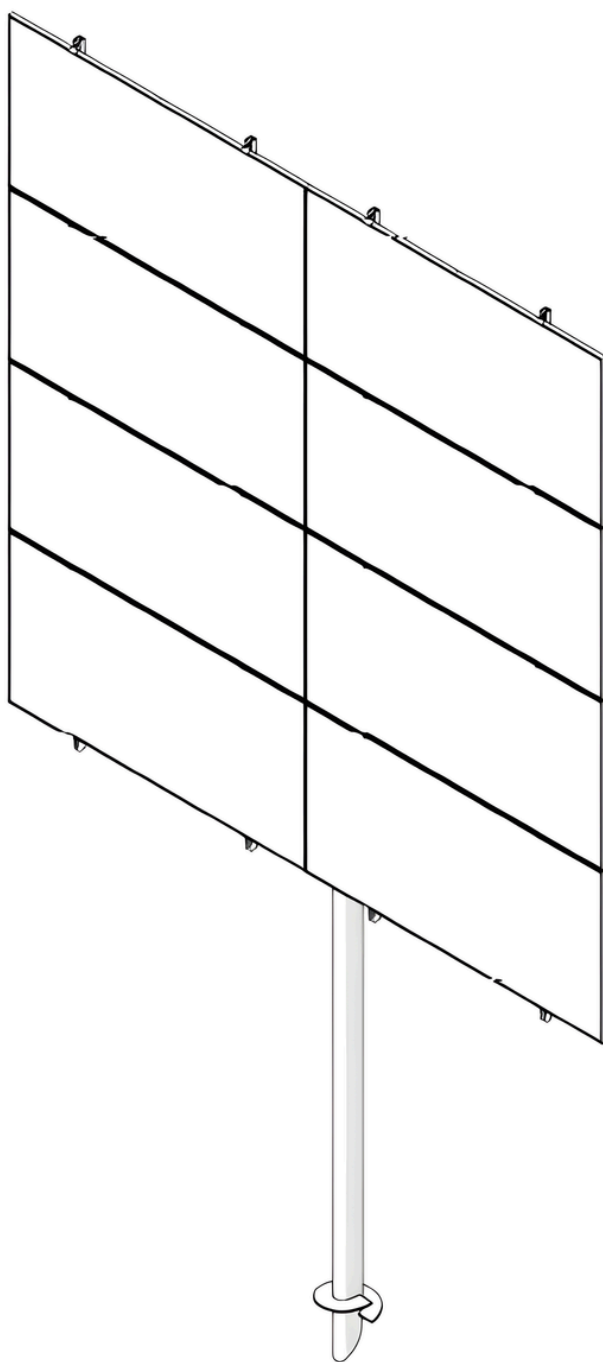

WITHOUT SOLAR PANELS

Assembled View

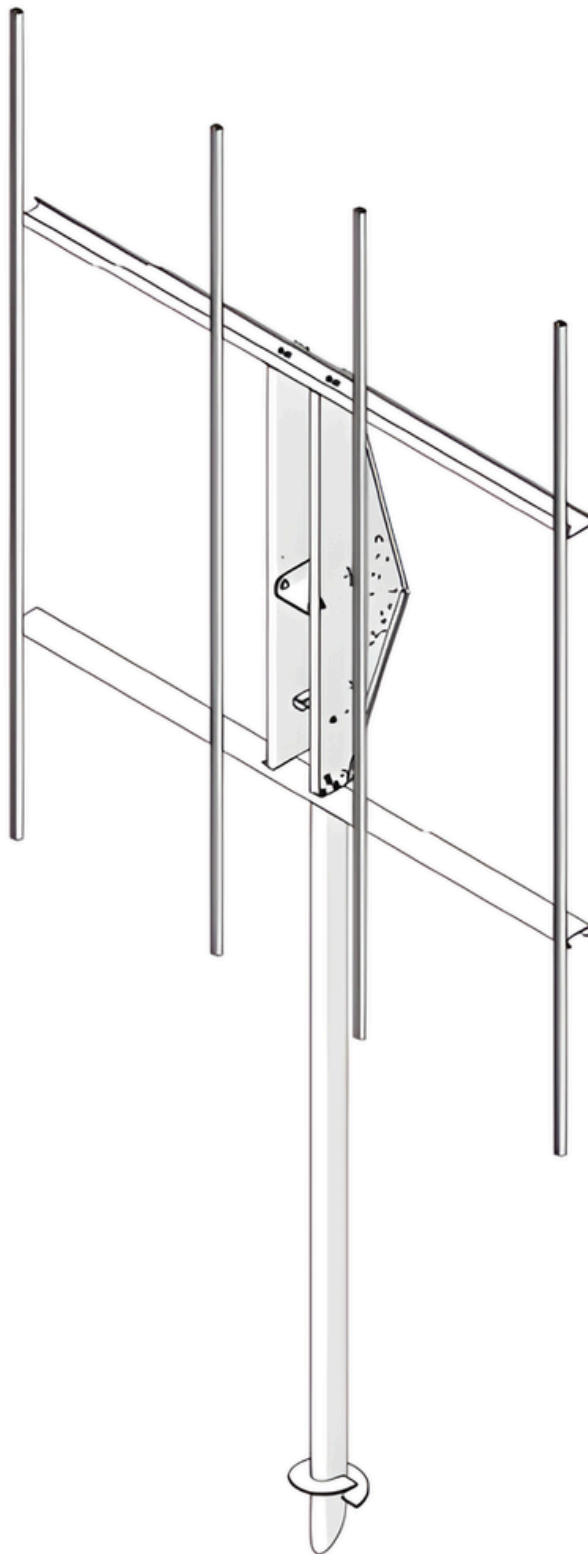

HELICAL SCREW PILE

Pivot Adapter Assembled View

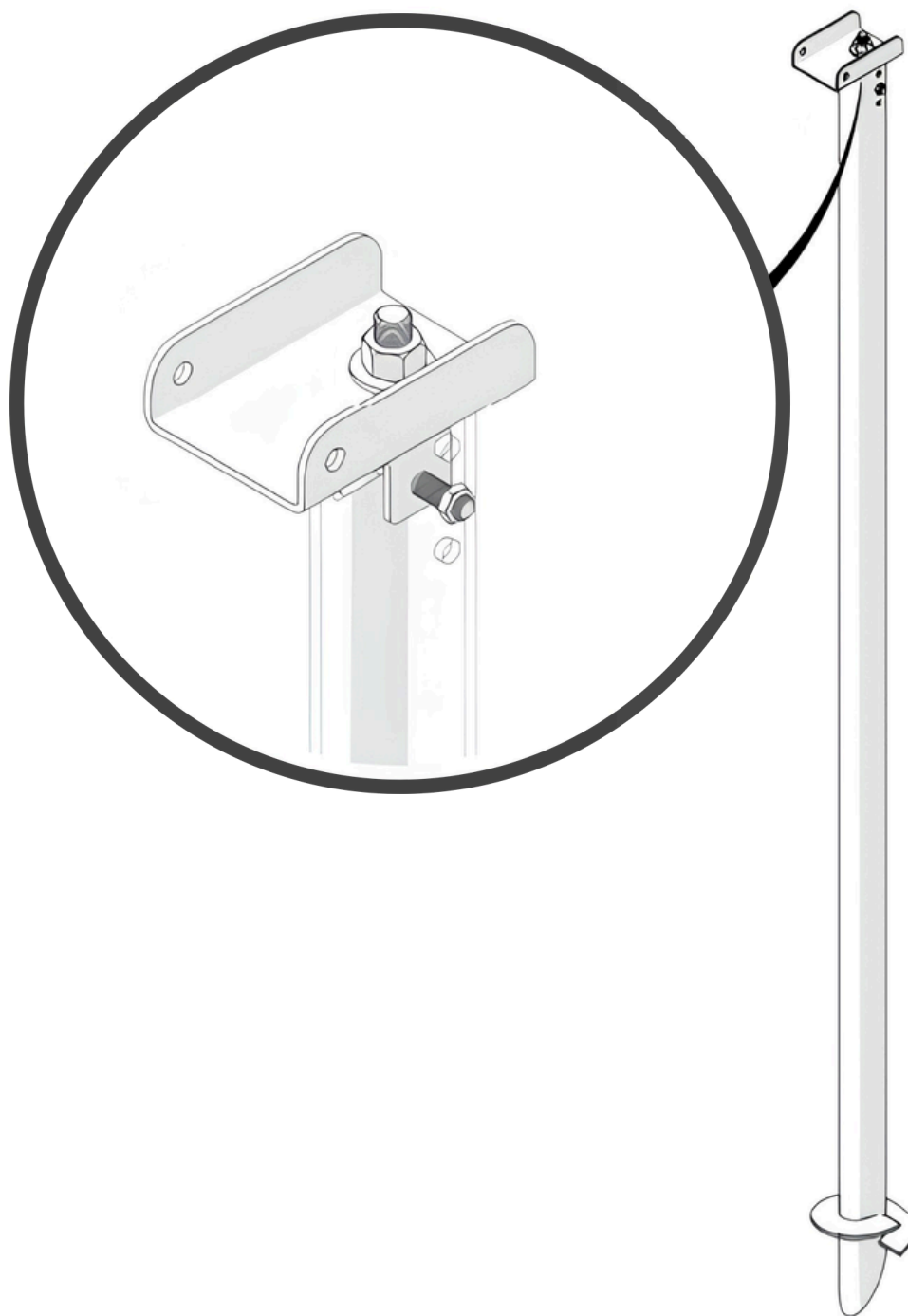

PILE INSERT

Assembly View

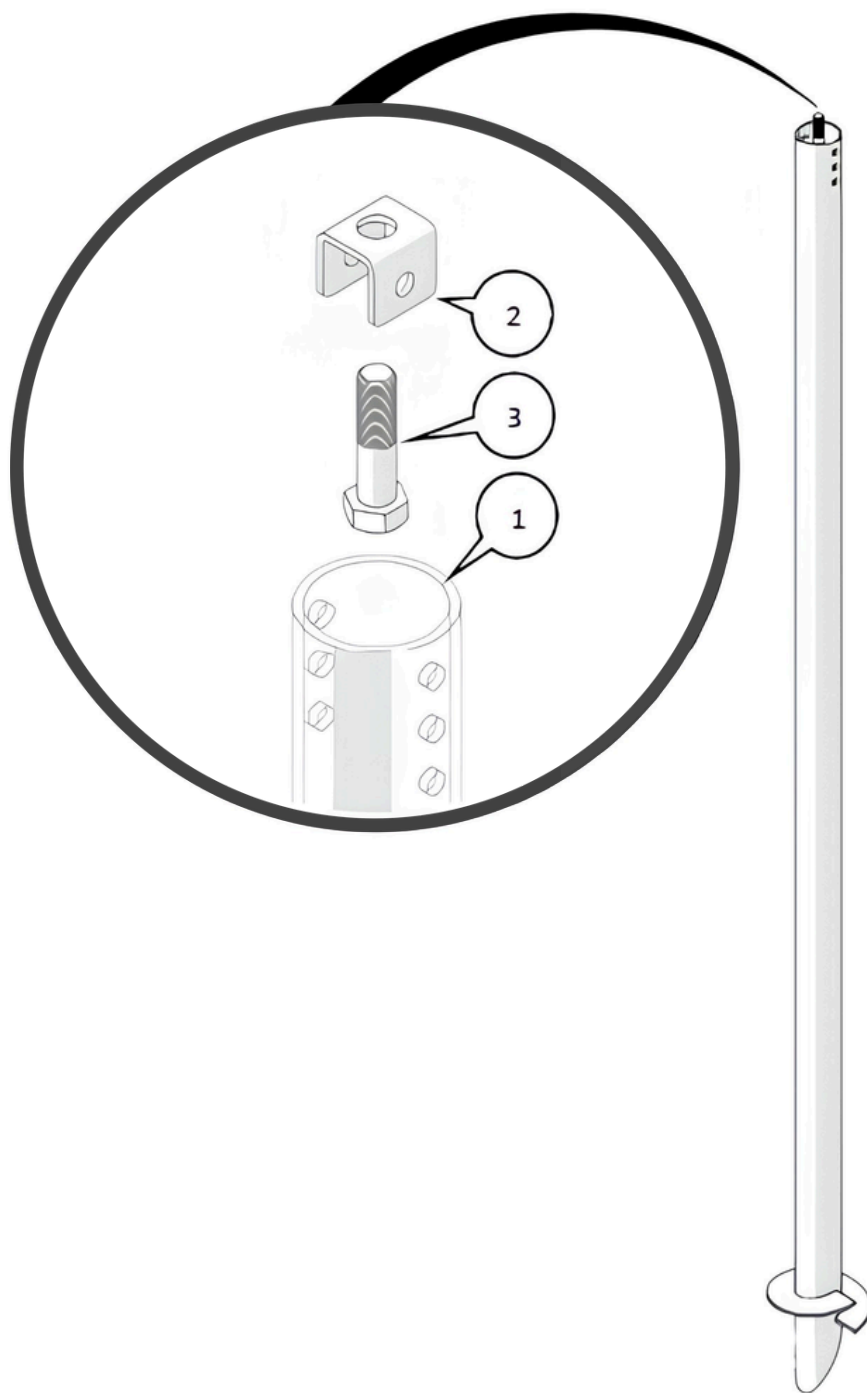

ITEM NO.	DESCRIPTION	QTY
1	HELICAL SCREW PILE	1
2	PILE INSERT	1
3	1 ½" x 6" BOLT	1

PILE INSERT

Assembly View

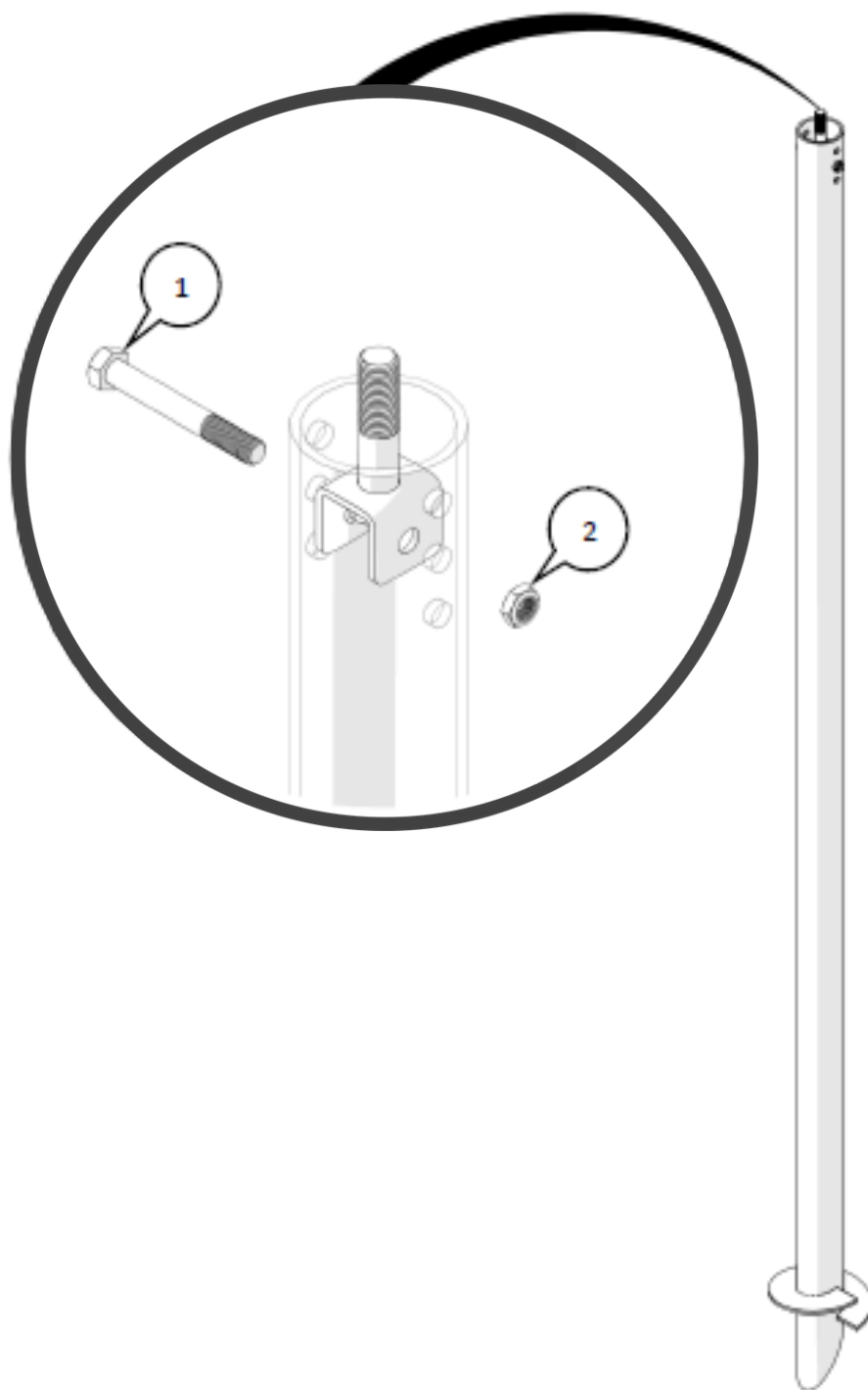

ITEM NO.	DESCRIPTION	QTY
1	1" x 7 1/2" BOLT	1
2	1" NYLOCK JAM NUT	1

PILE ADAPTER

Assembly View

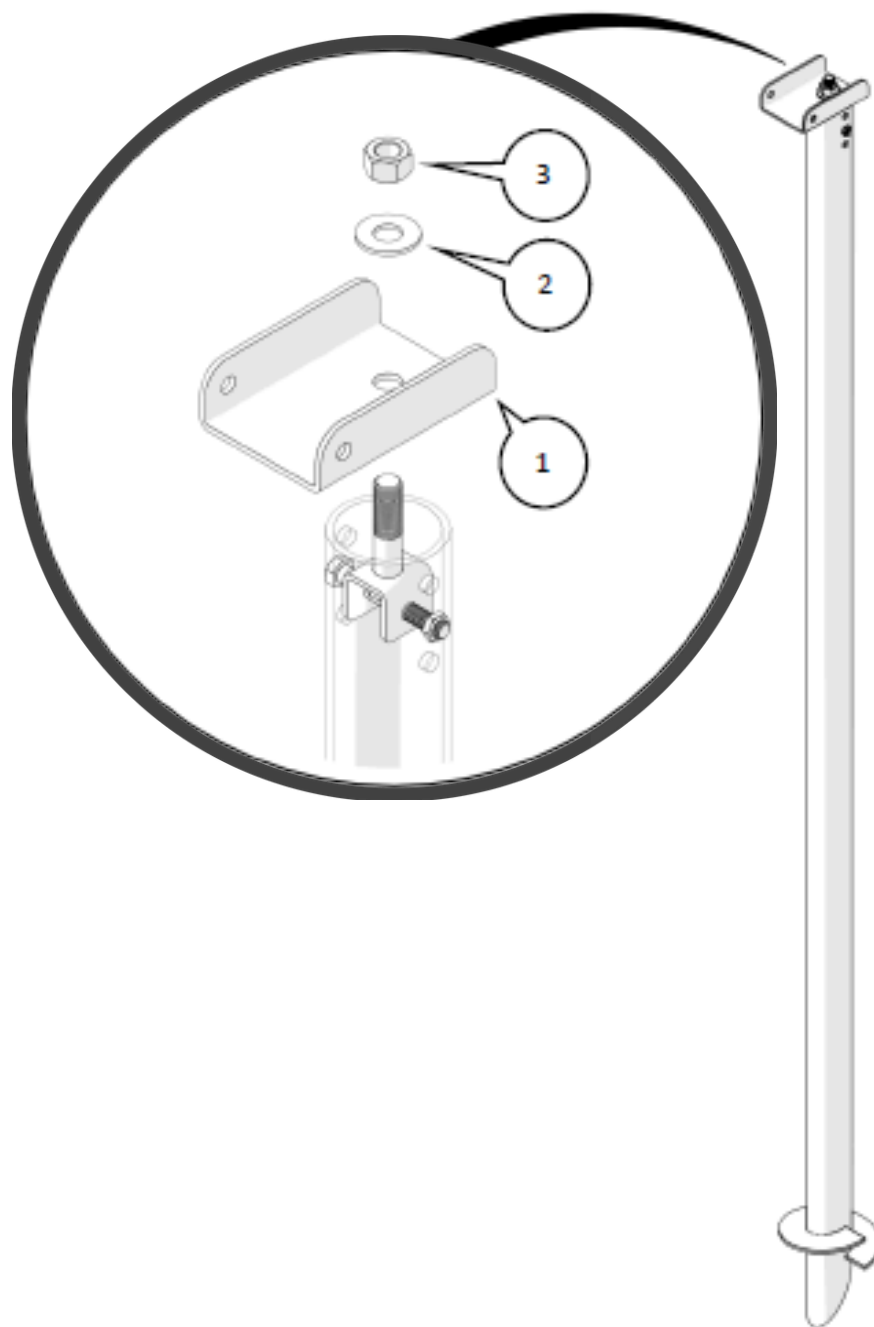

ITEM NO.	DESCRIPTION	QTY
1	PILE ADAPTER	1
2	1 ½" WASHER	1
3	1 ½" NUT	1

PIVOT PLATE

Assembly View

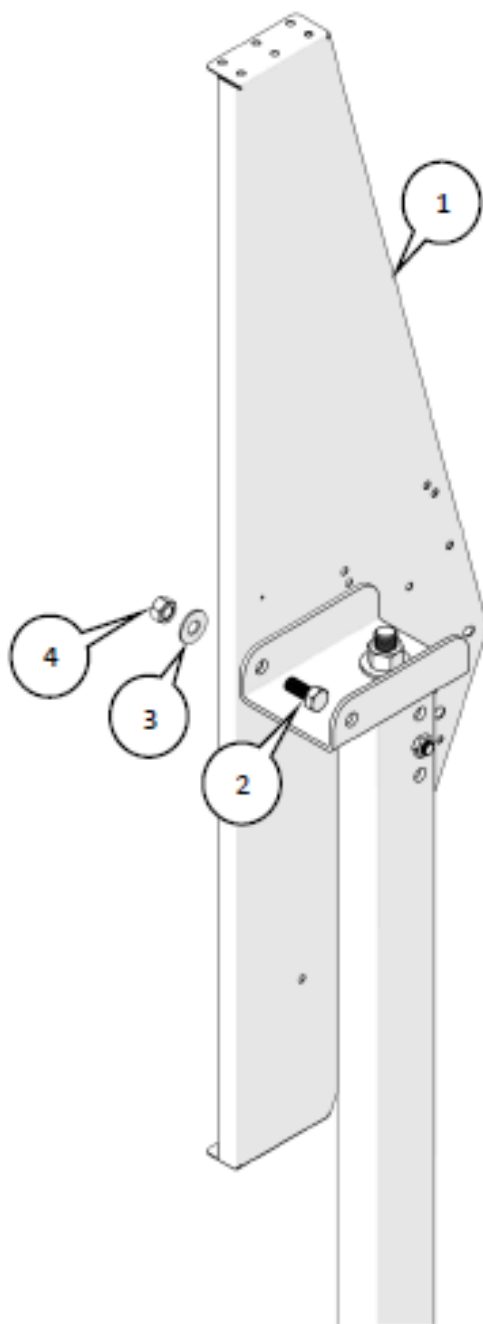

ITEM NO.	DESCRIPTION	QTY
1	PIVOT PLATE WEST	1
2	1" x 2 1/4" BOLT	1
3	1" WASHER	1
4	1" NUT	1

PIVOT PLATE

Assembly View

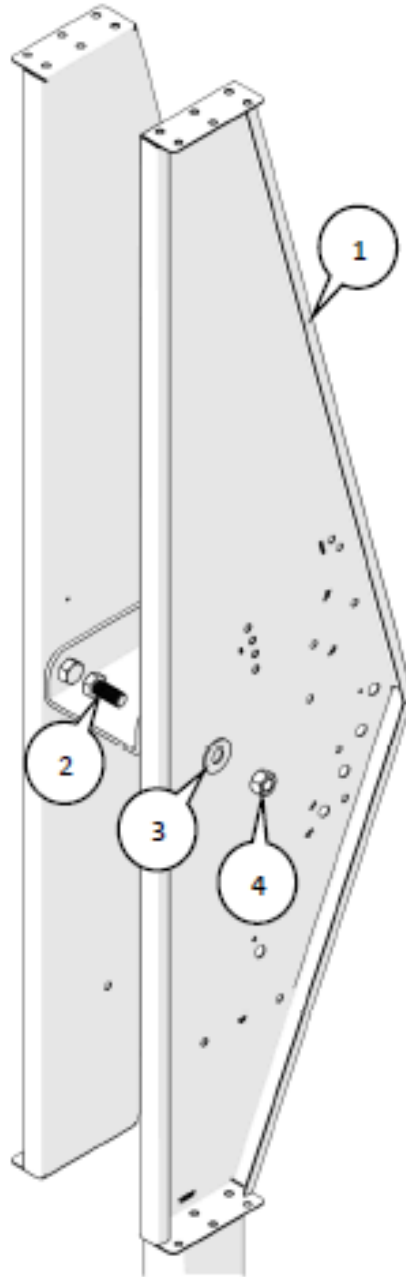

ITEM NO.	DESCRIPTION	QTY
1	PIVOT PLATE EAST	1
2	1" x 2 1/4" BOLT	1
3	1" WASHER	1
4	1" NUT	1

PILE SADDLES

Assembly View

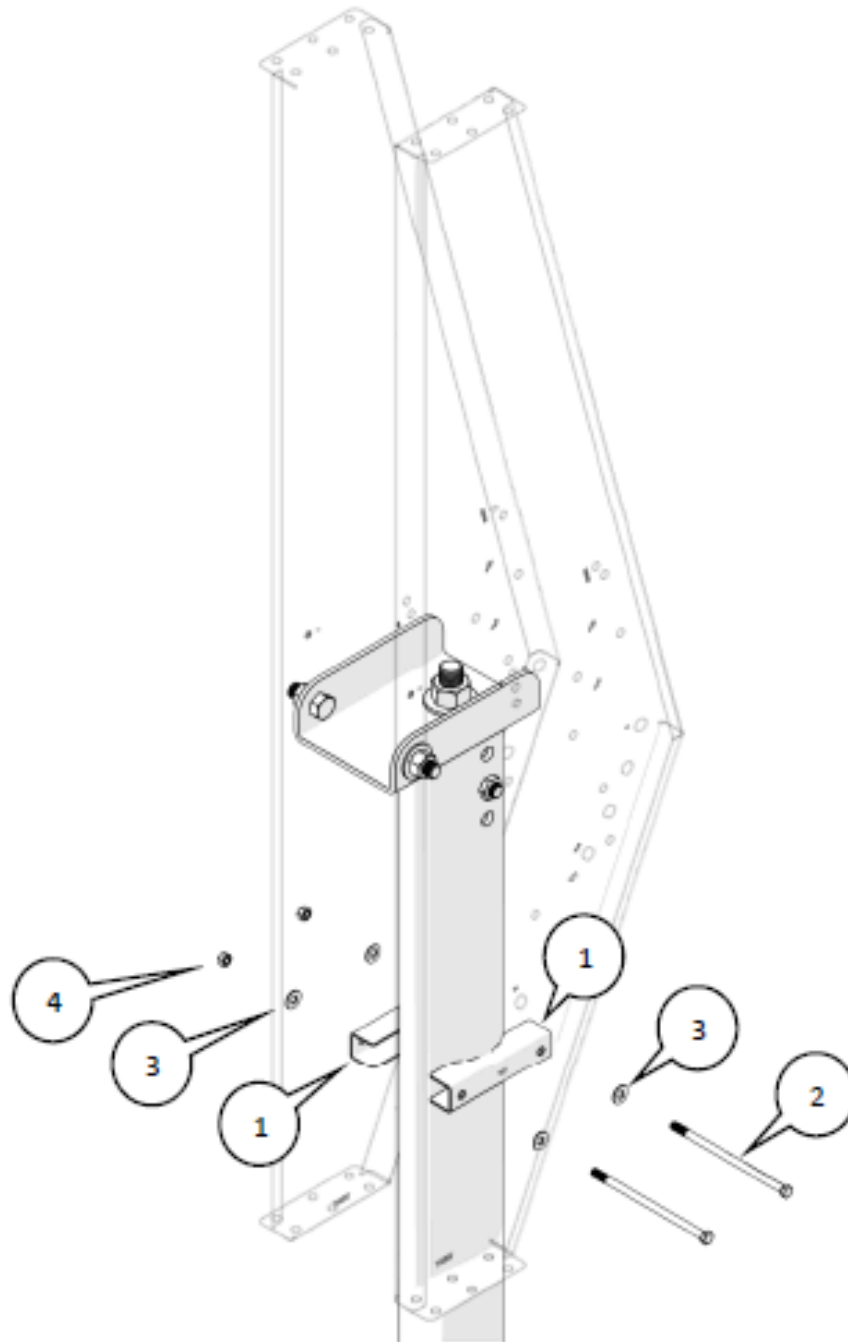

ITEM NO.	DESCRIPTION	QTY
1	PILE SADDLE	2
2	1/2" x 10" BOLT	2
3	1/2" WASHER	4
4	1/2" NUT	2

MAIN BEAM

Assembly View

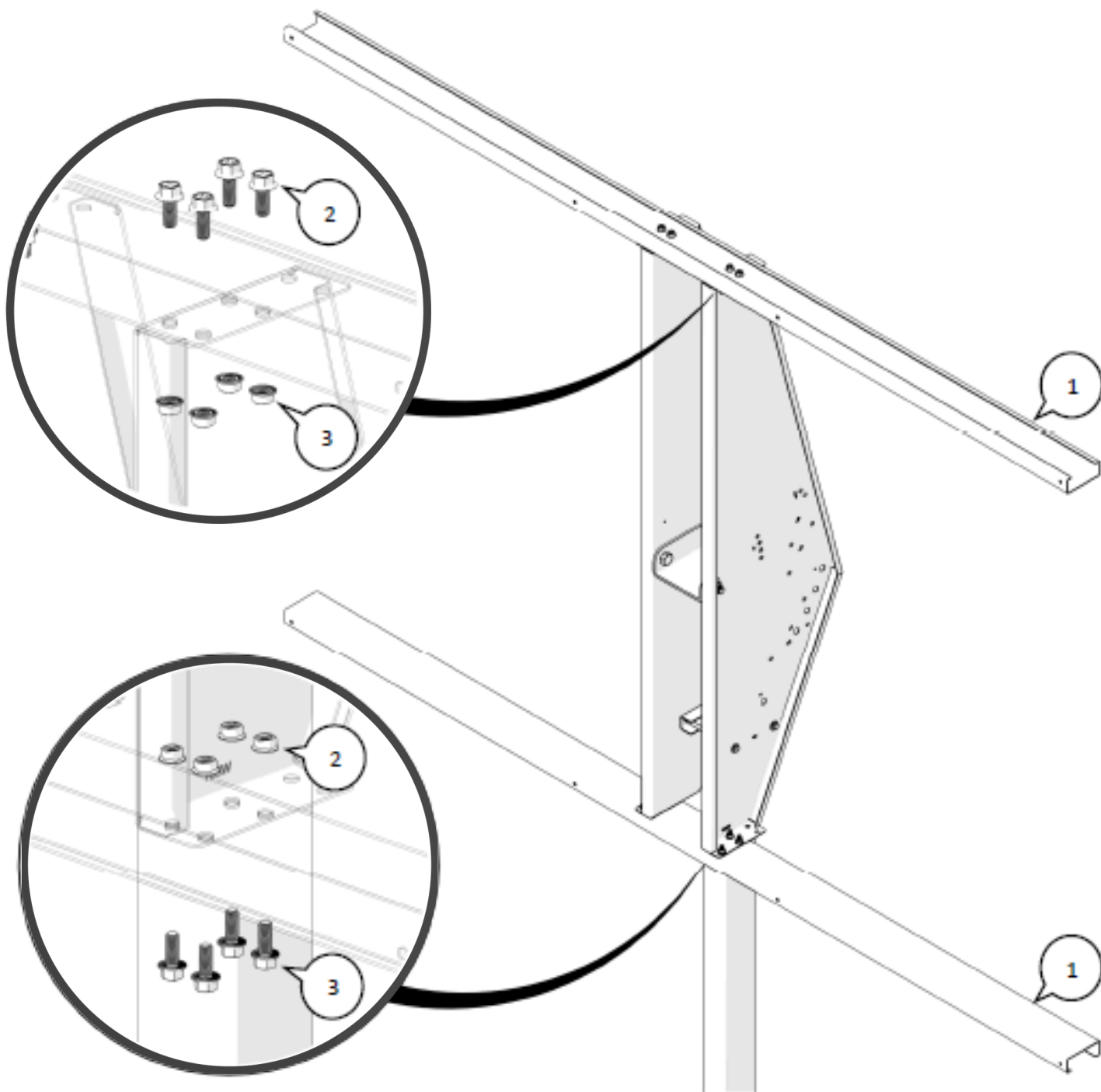

ITEM NO.	DESCRIPTION	QTY
1	MAIN BEAM	2
2	1/2" x 1 1/4" SERRATED FLANGE BOLT	16
3	1/2" SERRATED FLANGE NUT	16

PURLINS

Assembly View

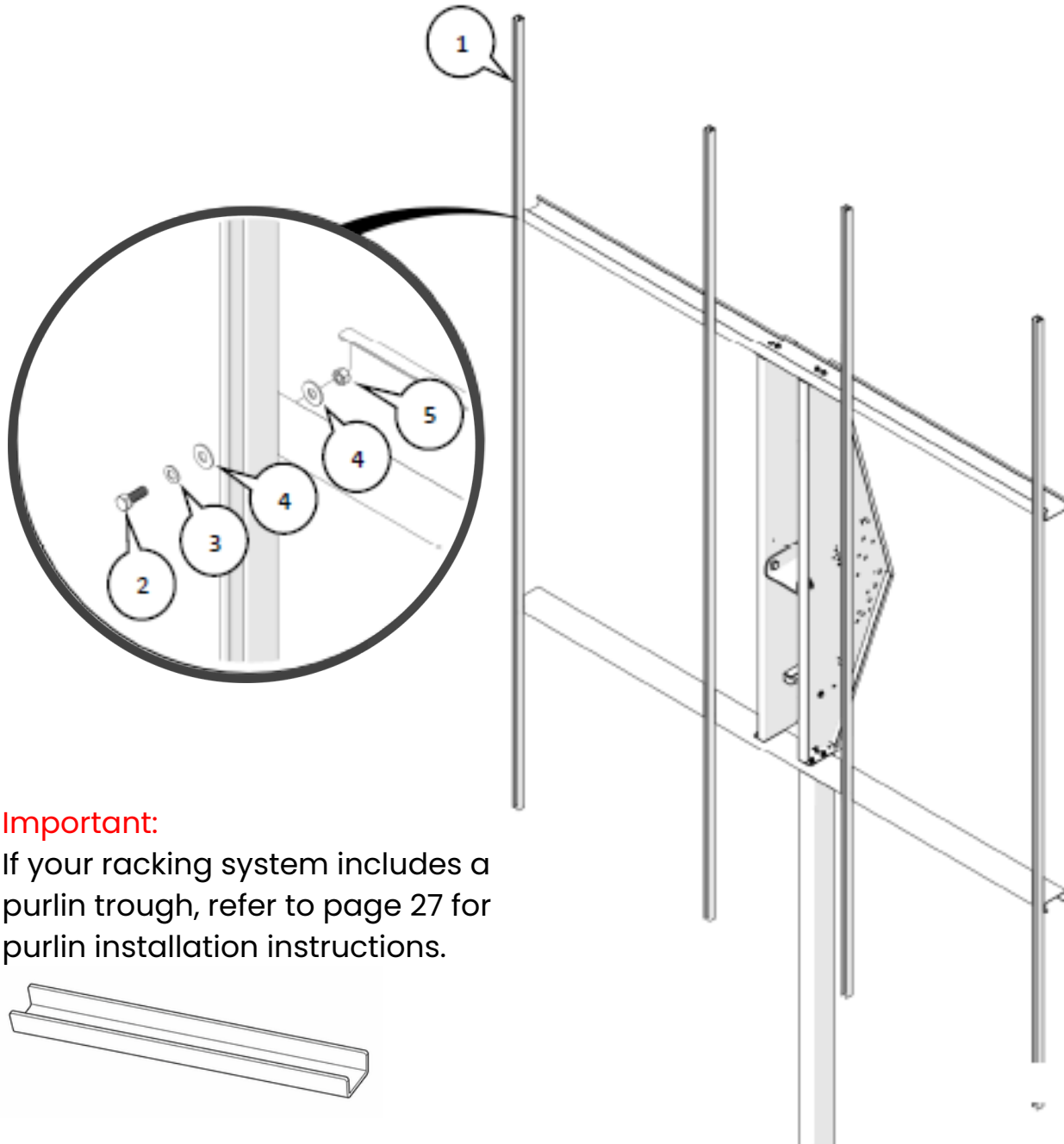

Important:

If your racking system includes a purlin trough, refer to page 27 for purlin installation instructions.

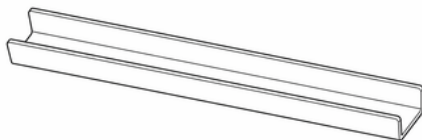

Note: purlins should extend past main beam at equal lengths all around

ITEM NO.	DESCRIPTION	QTY
1	PURLIN	4
2	3/8" x 1" BOLT	8
3	3/8" WASHER (Gr8 YELLOW COLOR)	8
4	3/8" WASHER	18
5	3/8" NYLOCK NUT	8

Z-CLIP

Assembly View

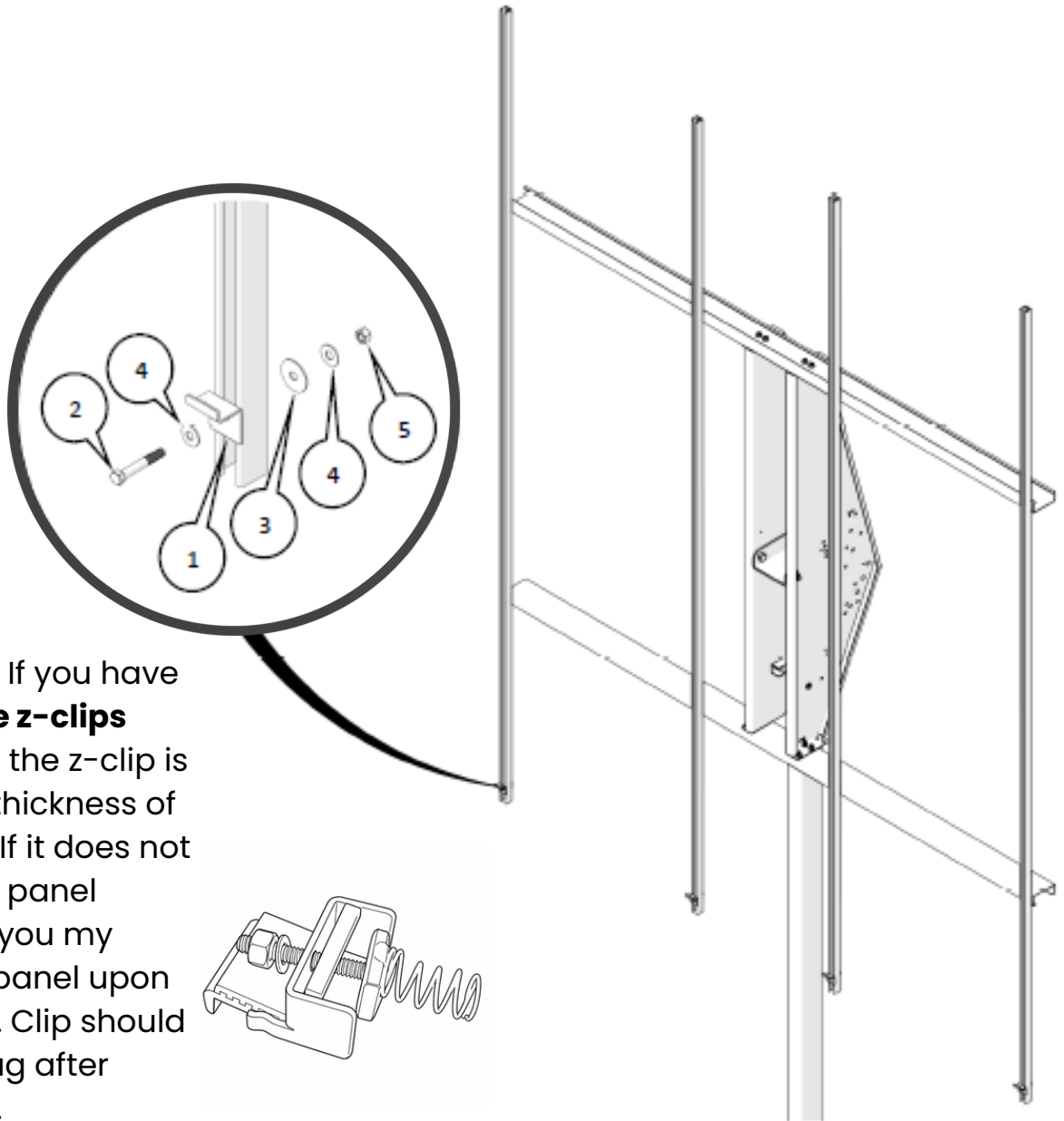

Important: If you have **adjustable z-clips** make sure the z-clip is set to the thickness of the panel. If it does not match the panel thickness, you may crack the panel upon tightening. Clip should just be snug after tightening.
(See page 29)

Note: z-clip hardware to be installed in second slot from bottom

ITEM NO.	DESCRIPTION	QTY
1	Z-Clip	4
2	5/16" x 2 1/2" Bolt	4
3	5/16" Fender Washer	4
4	5/16" Washer	8
5	5/16" Nylock Nut	4

SOLAR PANELS

Hardware Assembly View

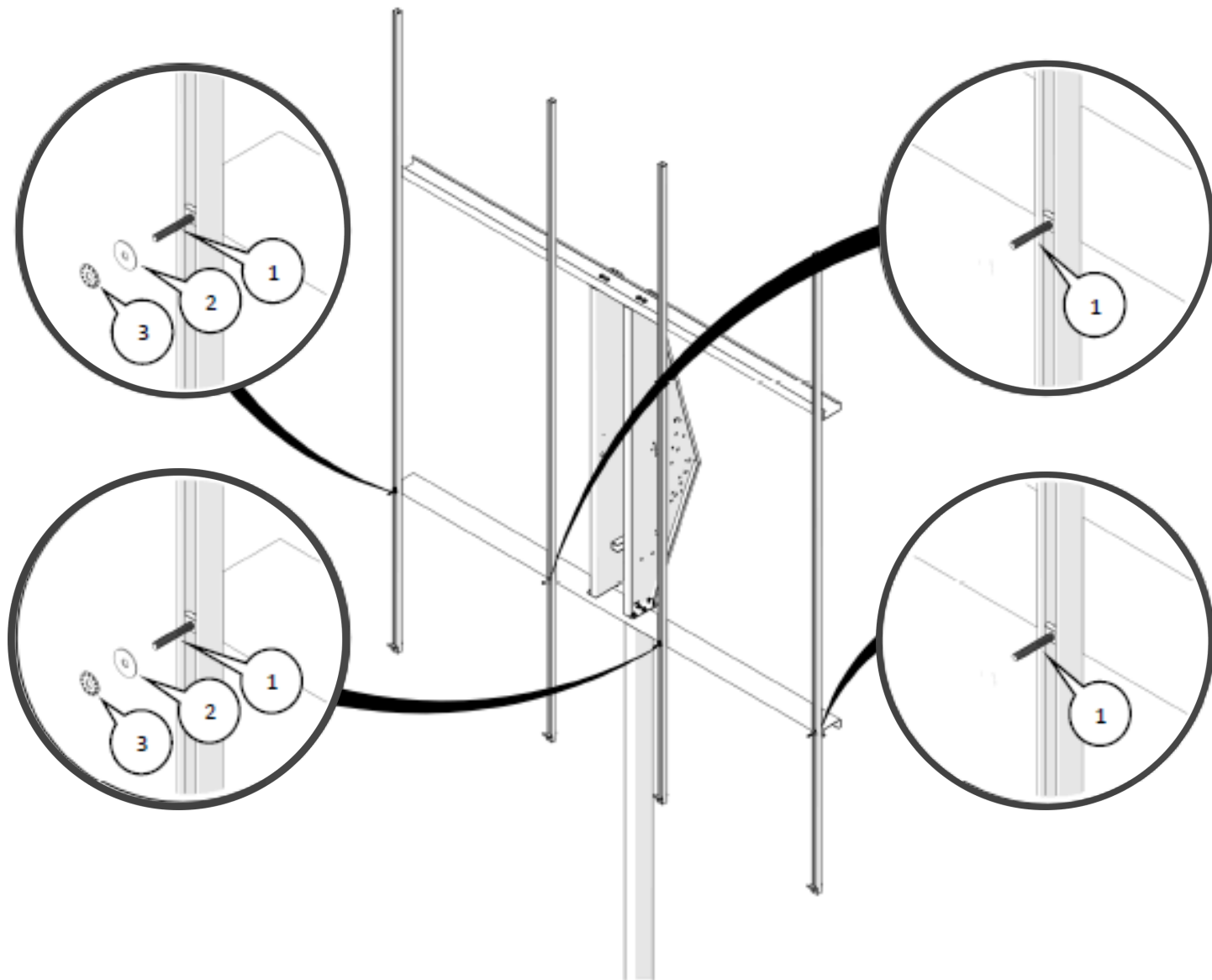

ITEM NO.	DESCRIPTION	QTY
1	SPRING STUD	4
2	3/8" FENDER WASHER	2
3	3/8" BONDING WASHER	2

SOLAR PANELS

First Row Assembly View

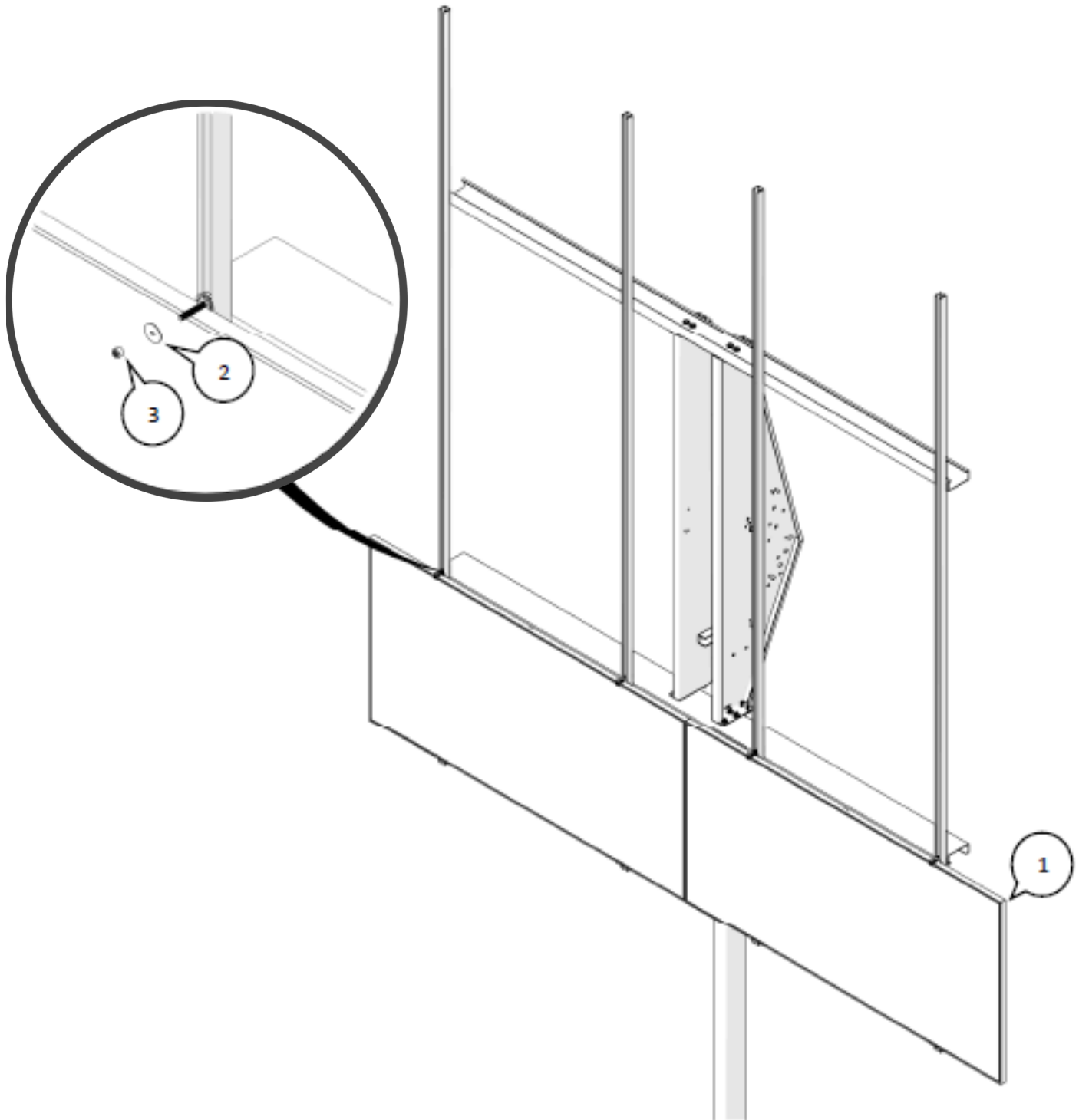

ITEM NO.	DESCRIPTION	QTY
1	SOLAR PANEL	2
2	3/8" FENDER WASHER	4
3	3/8" NYLOCK NUT	4

SOLAR PANELS

Hardware Assembly View

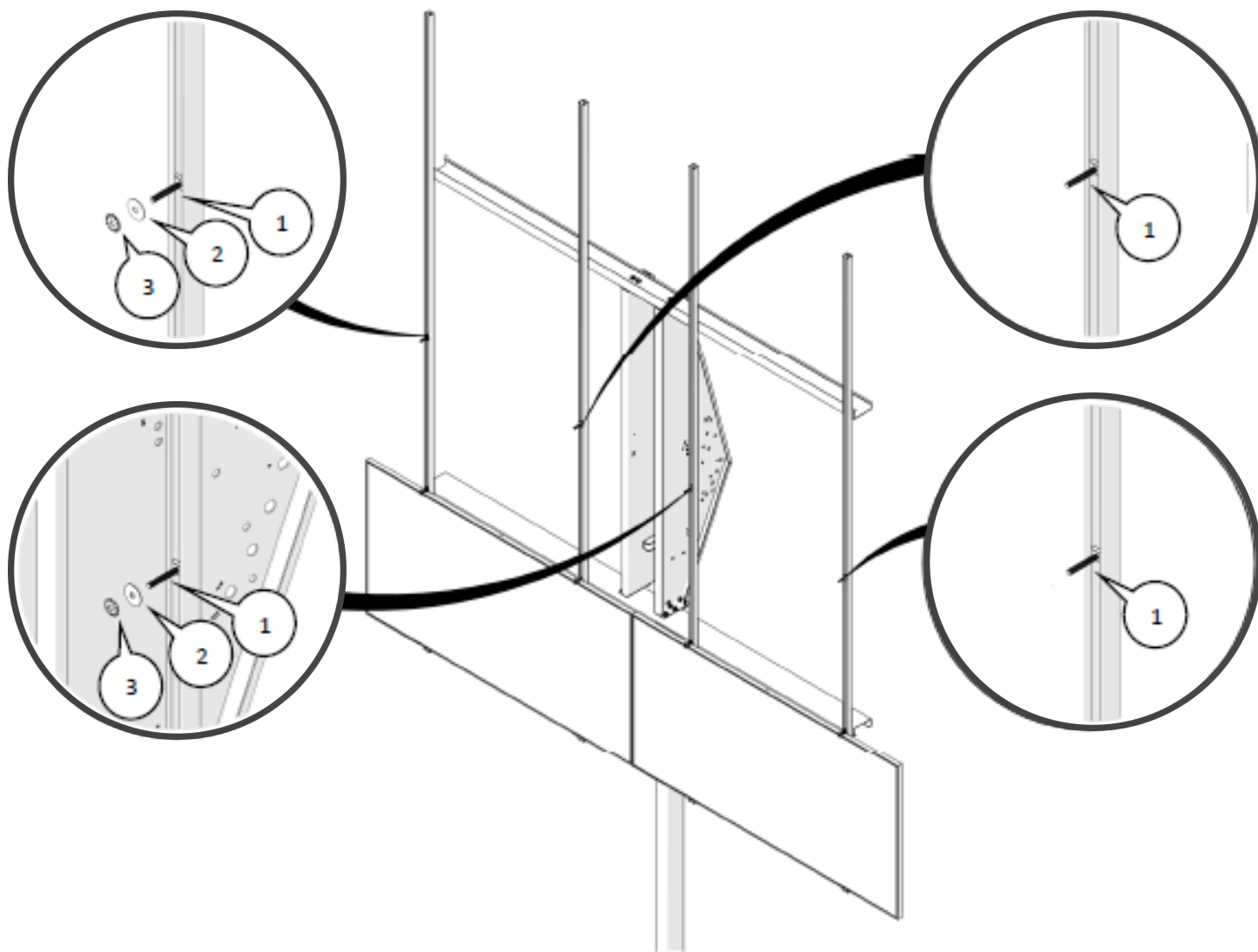

ITEM NO.	DESCRIPTION	QTY
1	SPRING STUD	4
2	3/8" FENDER WASHER	2
3	3/8" BONDING WASHER	2

SOLAR PANELS

Second Row Assembly View

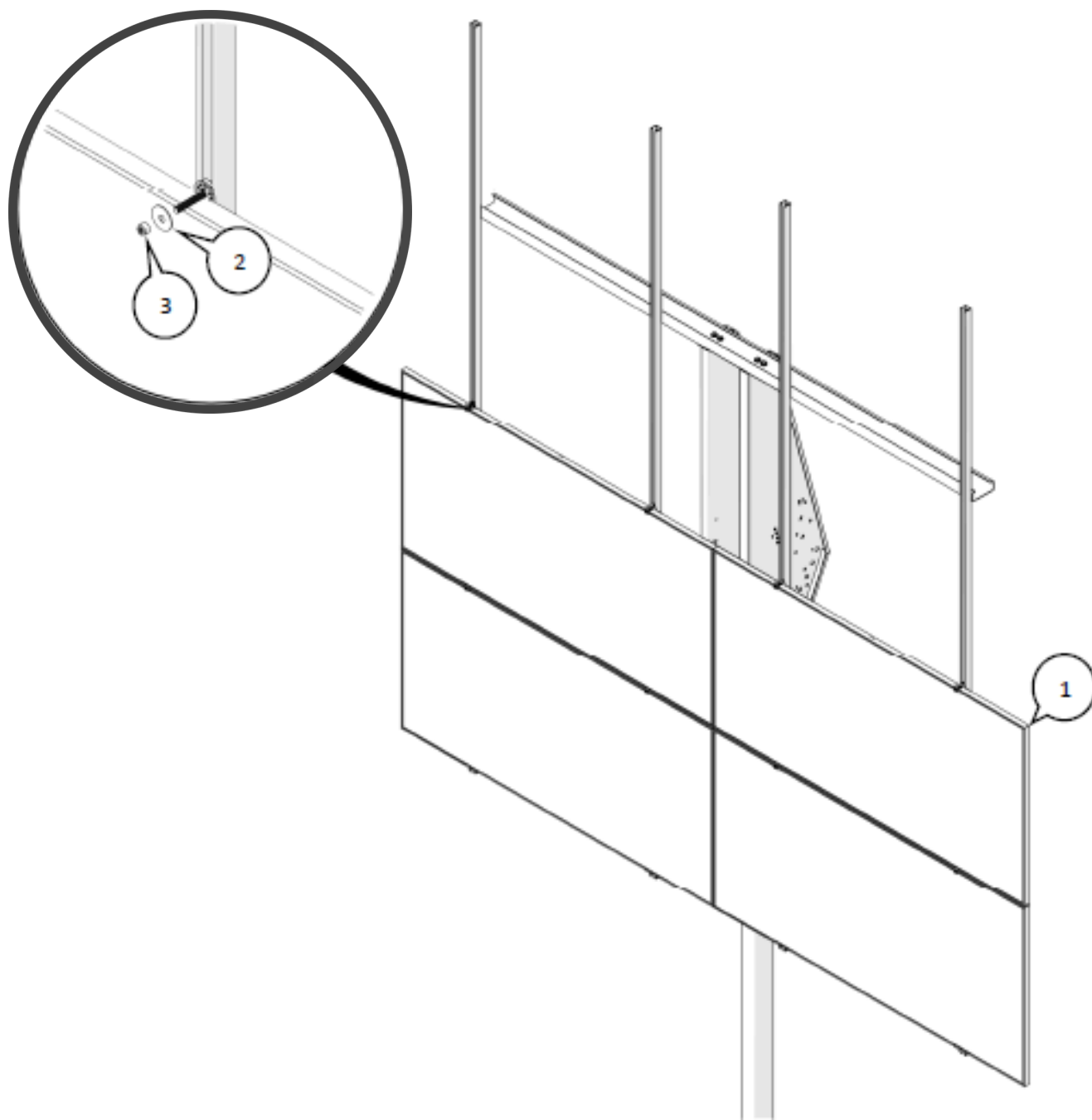

ITEM NO.	DESCRIPTION	QTY
1	SOLAR PANEL	2
2	3/8" FENDER WASHER	4
3	3/8" NYLOCK NUT	4

SOLAR PANELS

Hardware Assembly View

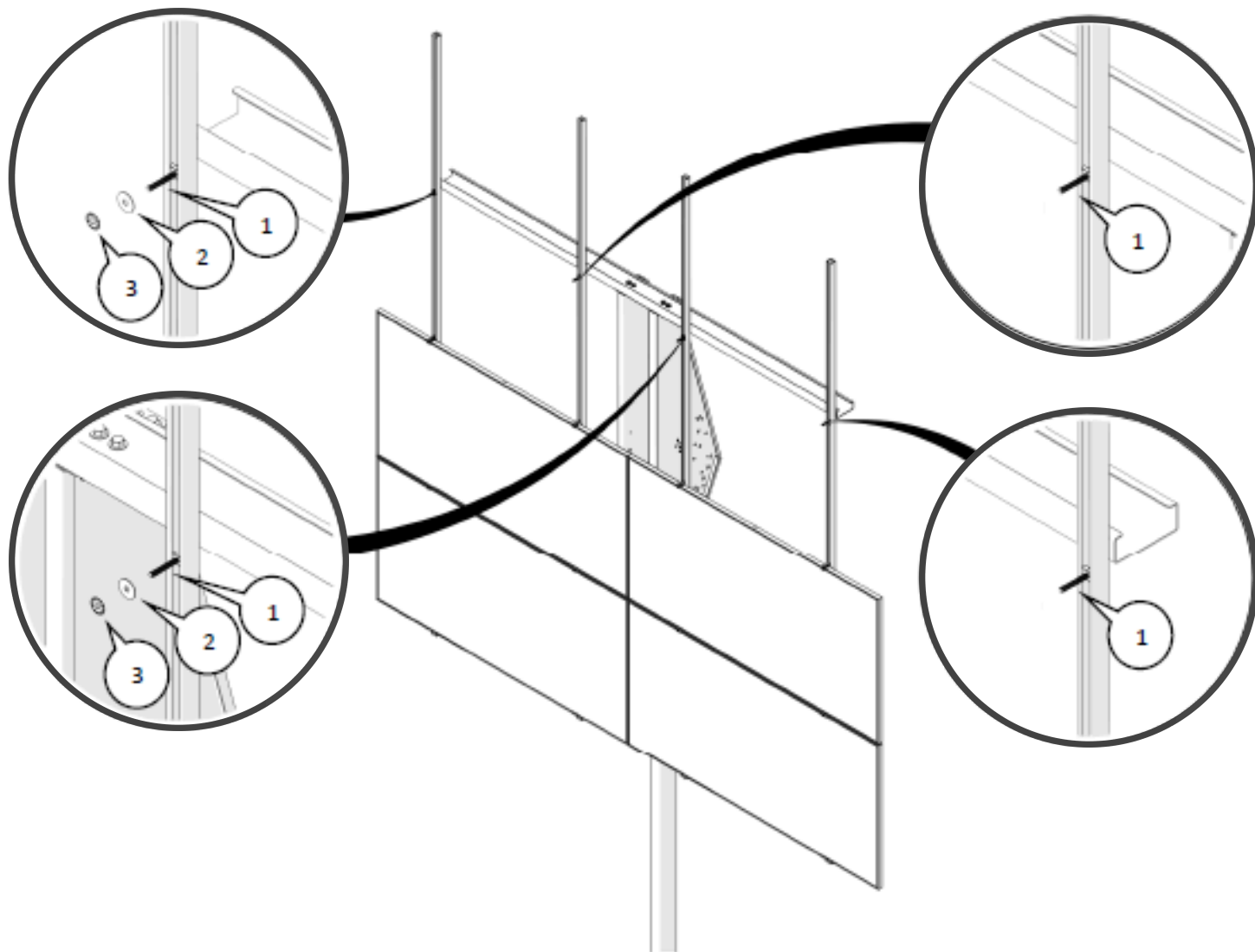

ITEM NO.	DESCRIPTION	QTY
1	SPRING STUD	4
2	3/8" FENDER WASHER	2
3	3/8" BONDING WASHER	2

SOLAR PANELS

Third Row Assembly View

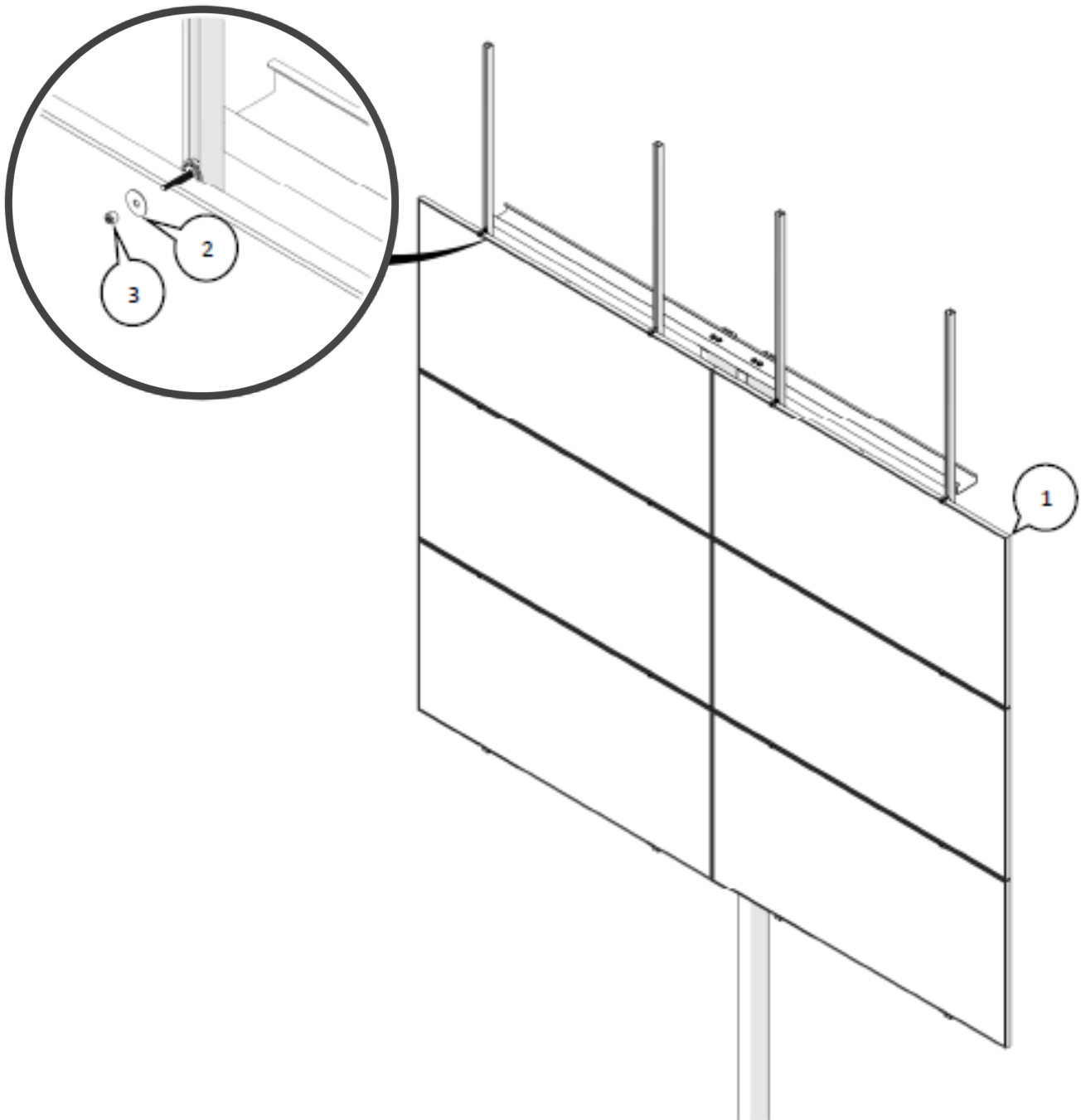

ITEM NO.	DESCRIPTION	QTY
1	SOLAR PANEL	2
2	3/8" FENDER WASHER	4
3	3/8" NYLOCK NUT	4

SOLAR PANELS

Fourth Row Assembly View

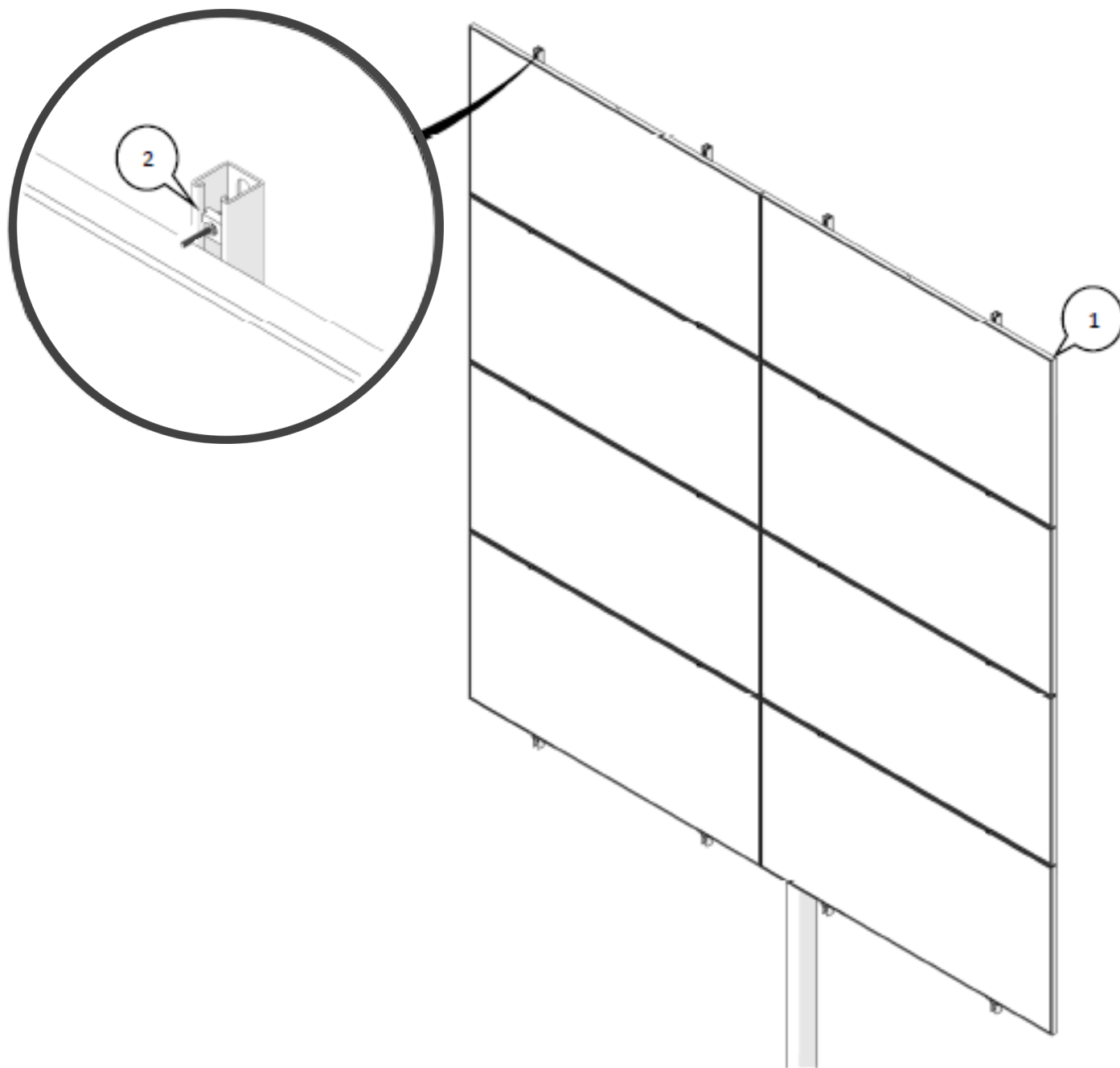

ITEM NO.	DESCRIPTION	QTY
1	Solar Panel	2
2	5/16" Spring Stud	4

Z-CLIP

Assembly View

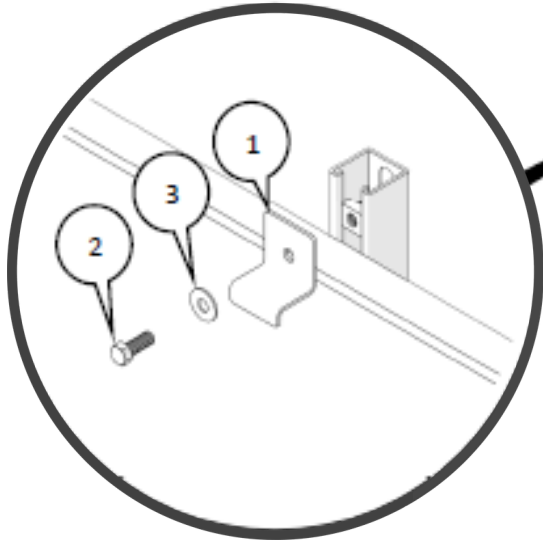

Important: If you have **adjustable z-clips** make sure the z-clip is set to the thickness of the panel. If it does not match the panel thickness, you may crack the panel upon tightening. Clip should just be snug after tightening.
(See page 29)

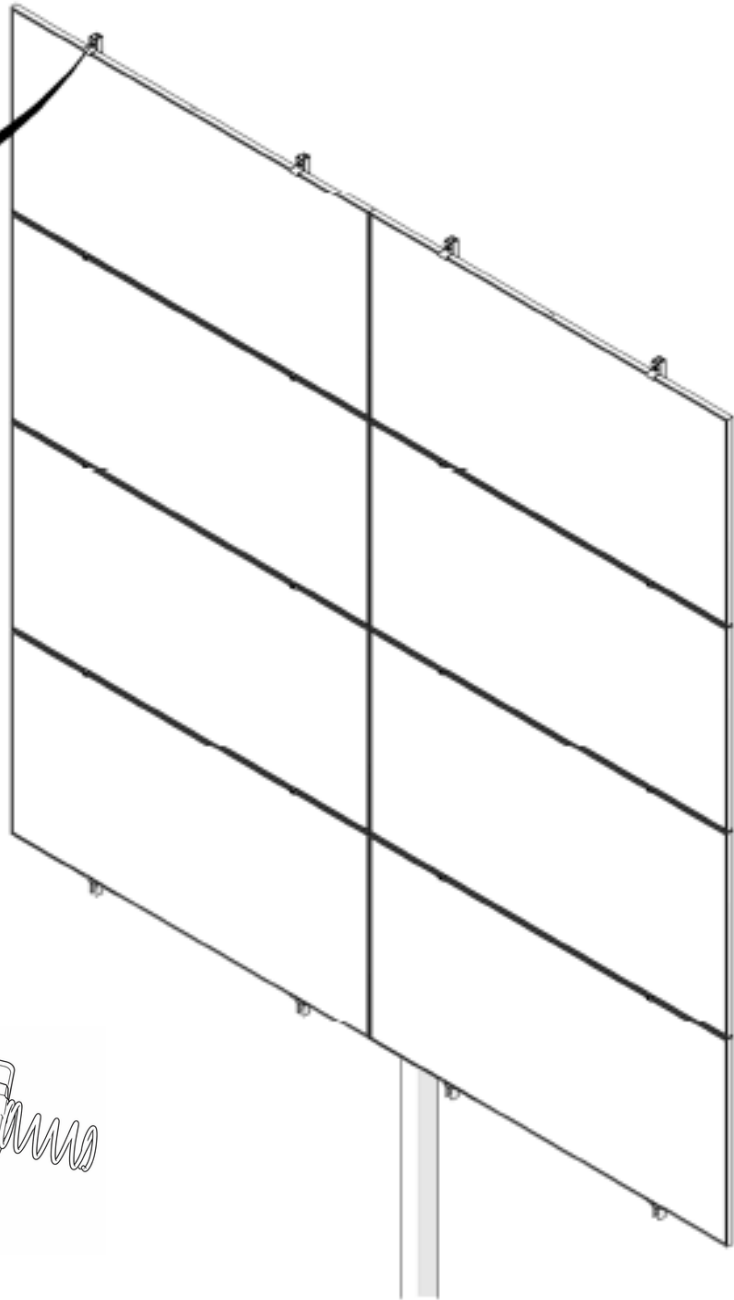
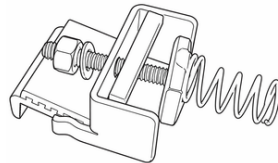

ITEM NO.	DESCRIPTION	QTY
1	Z-Clip	4
3	5/16" Washer	4
4	5/16" Nylock nut	4

SunRanger® Monopole ST-8L

Assembly View

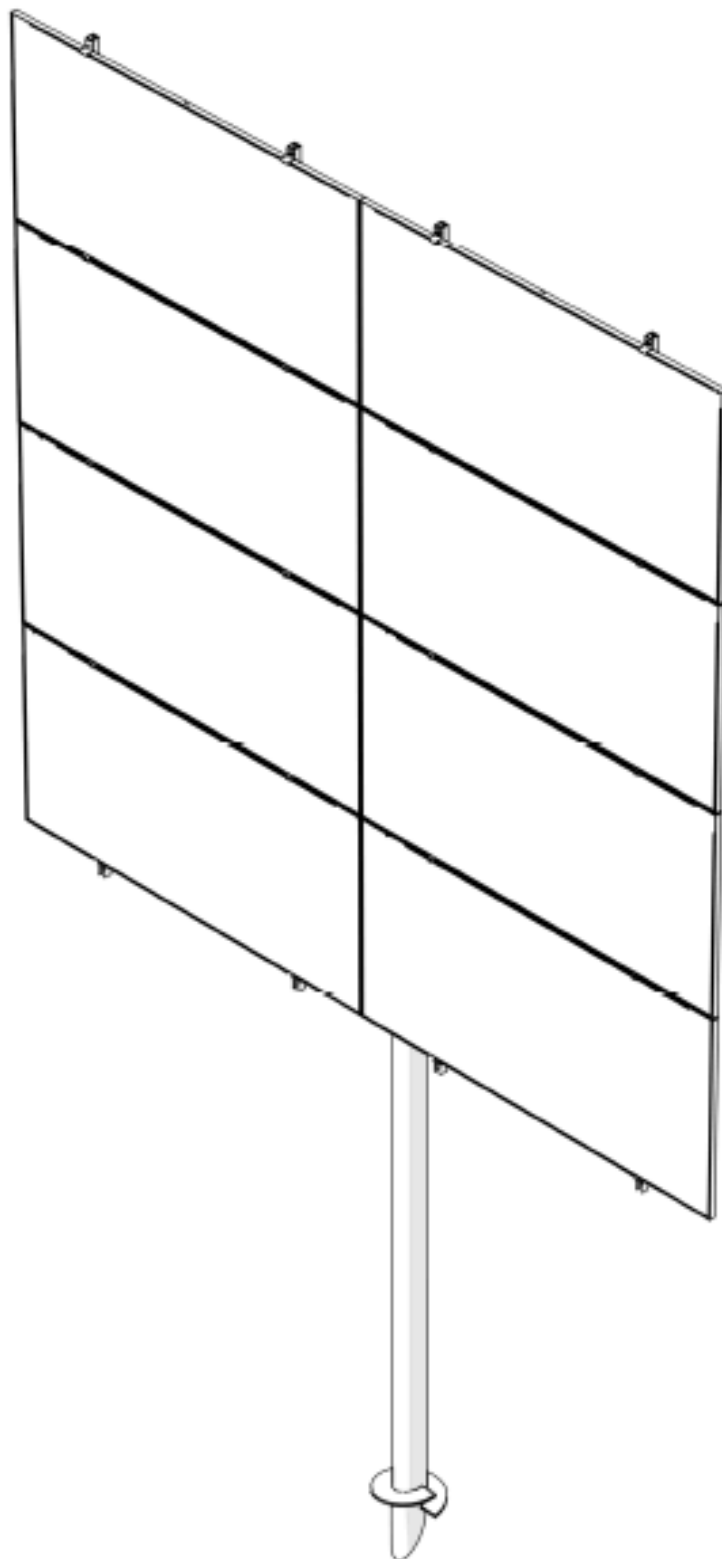

Section 2

Field References with photo's and configuration options!

These are NOT steps — they are enhancements to the steps in section 1.

Contents:

- Purlin Location 26
- Purlin Troughs 27
- Solar Module Installation (Option 1) 28
- Solar Module Installation (Option 2) 29
- Panel Bolting Detail 30
- Solar Module Installation31

Purlin Location

Before installing the purlins pre-mark both ends of the purlin with the slot that is 47 inches or the 24th slot from the bottom ends of the purlin and 47 inches or the 24th slot from the top of the purlins.

OR

Center the purlins between the two horizontal beams.

Beam length and location on the beam may vary depending on the solar panels used.

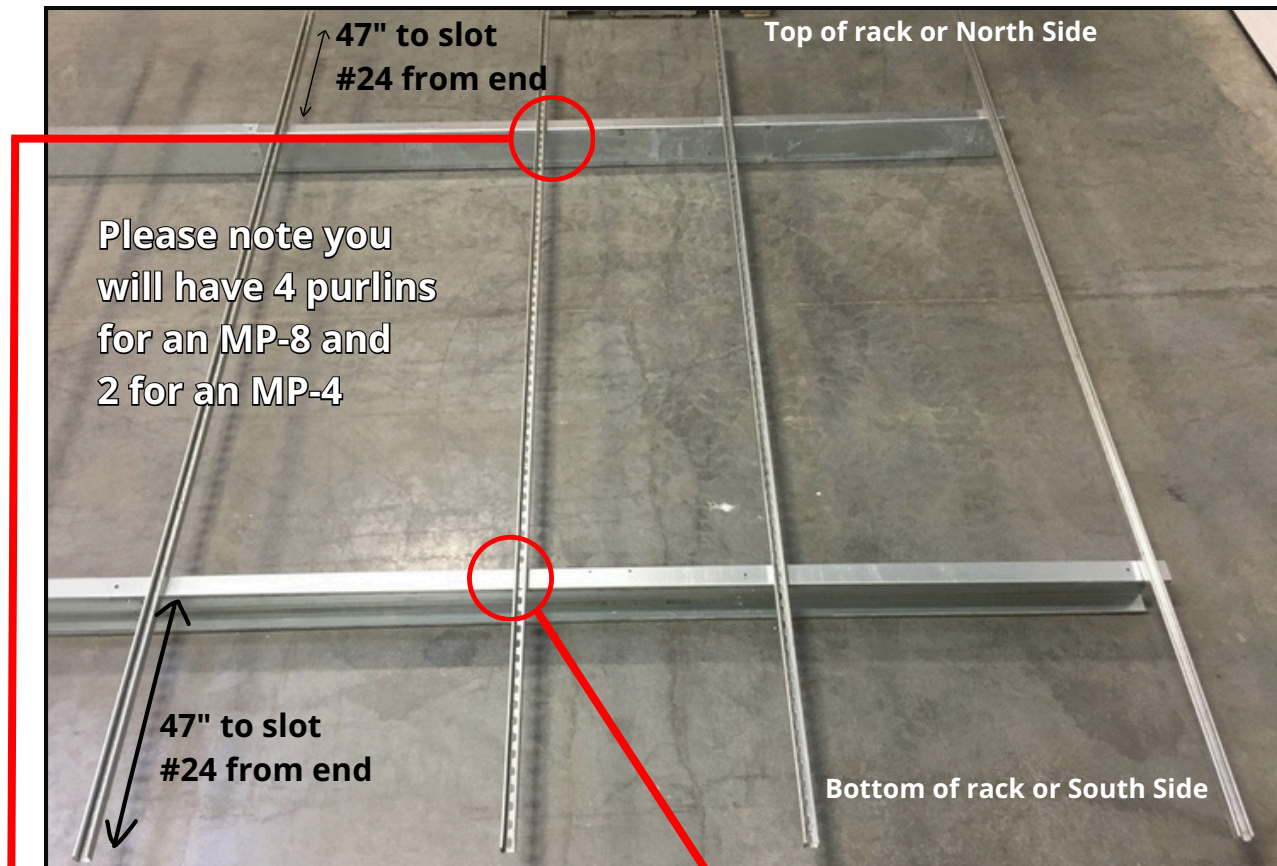

Bolt sits on top of the slot



Bolt sits on bottom of the slot



Purlin Troughs

Purlin troughs attach where the purlin meets the beam both top and bottom.

Pivot Plate to Beam Hardware

- 1/2" Serrated Bolt
- 1/2" Serrated Nut

Note: there are 3 bolts per purlin trough

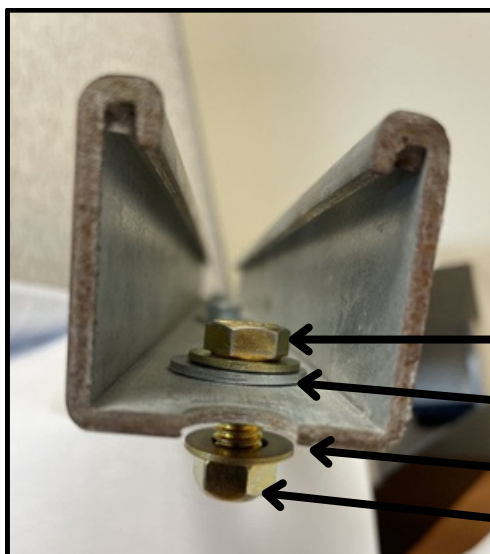
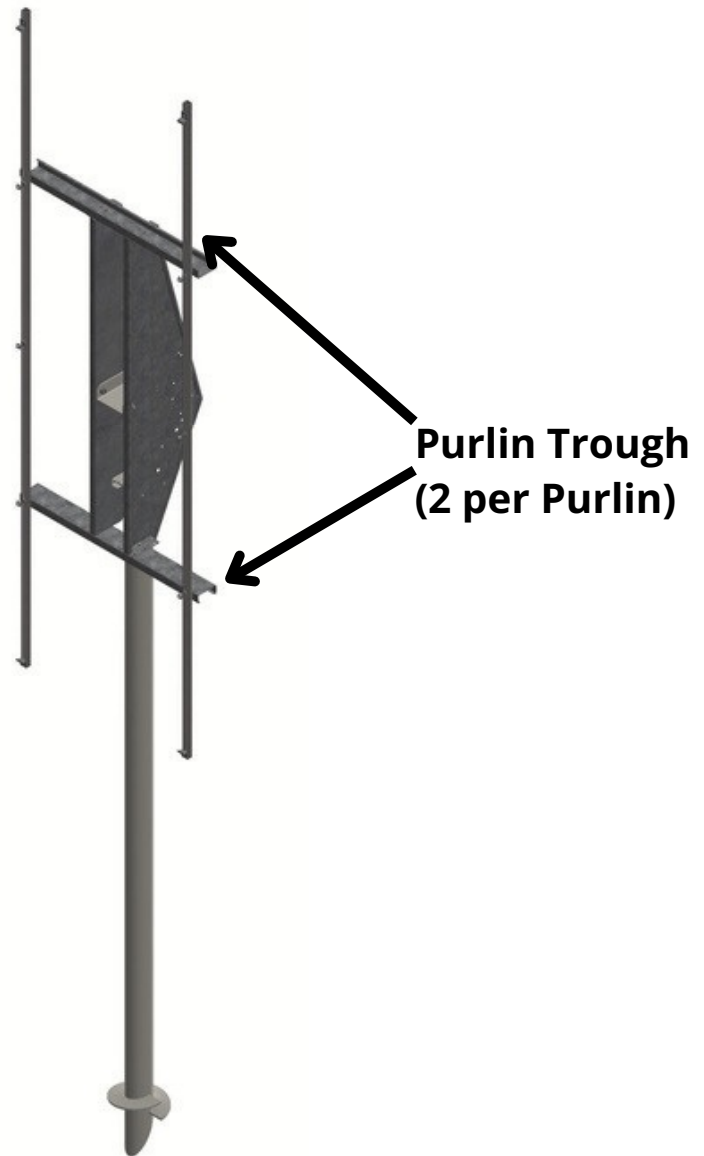
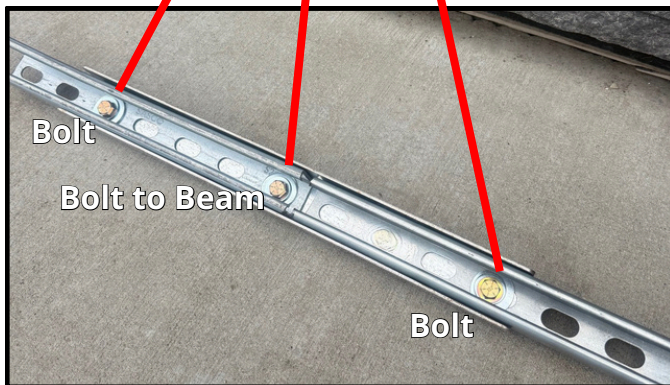
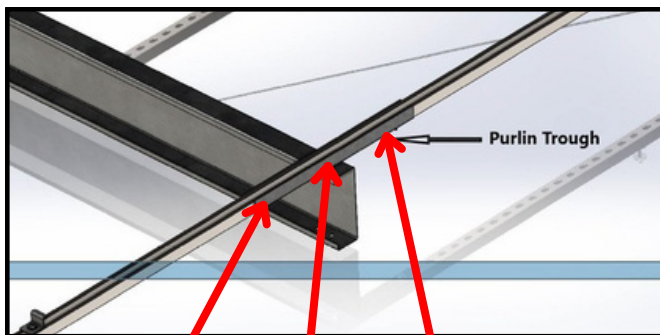

IMPORTANT:

Purlin to Beam Bolt

- Bolt (3/8" x 1")
- Washer x 2
- Single Washer
- Nut

Solar Module Installation (Option 1)

Top Z-clip Hardware

- 3/8" x 1-1/2" short spring stud
- 3/8" flat washer
- 3/8" nyloc nut

Install the bottom (South) Z-clips to the lower end of the purlins.

The fender washer will be on the bottom of the purlin with the Z-clips at the top.

Bottom Z-clip Hardware

- 3/8" x 2-1/2" bolt
- 3/8" fender washer
- 3/8" flat washer
- 3/8" nyloc nut

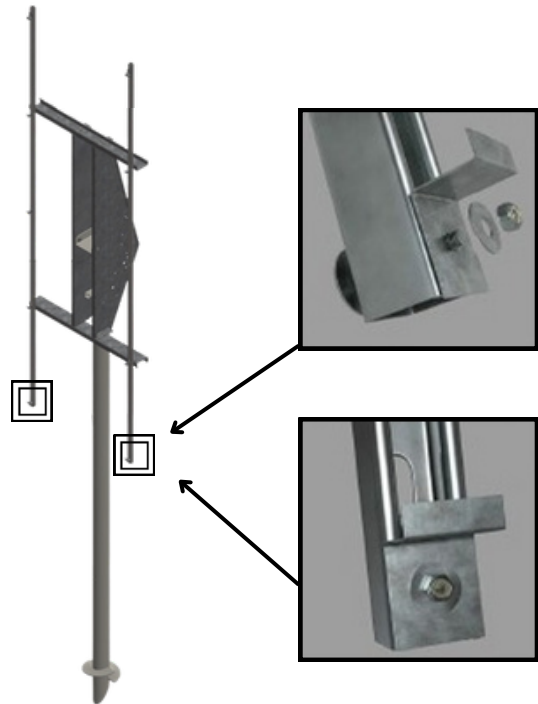

Depending on the solar panel used you may wish to trim excess purlin length on top and or bottom, but excess purlin length may be left as is..

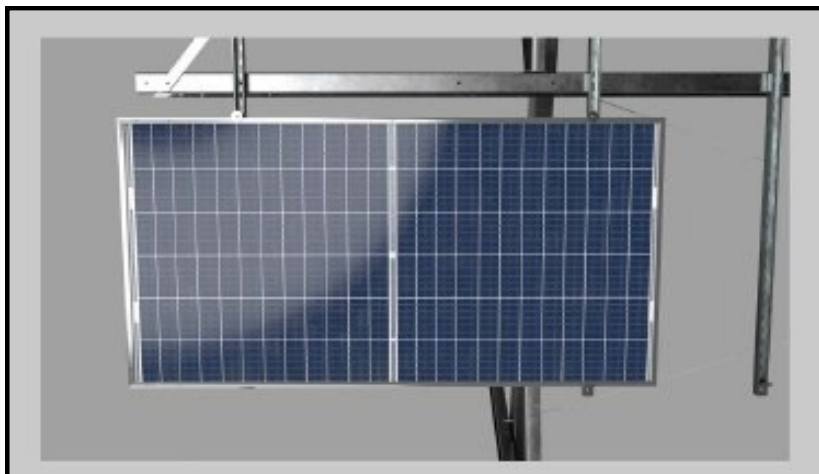

Solar Module Installation (Option 2)

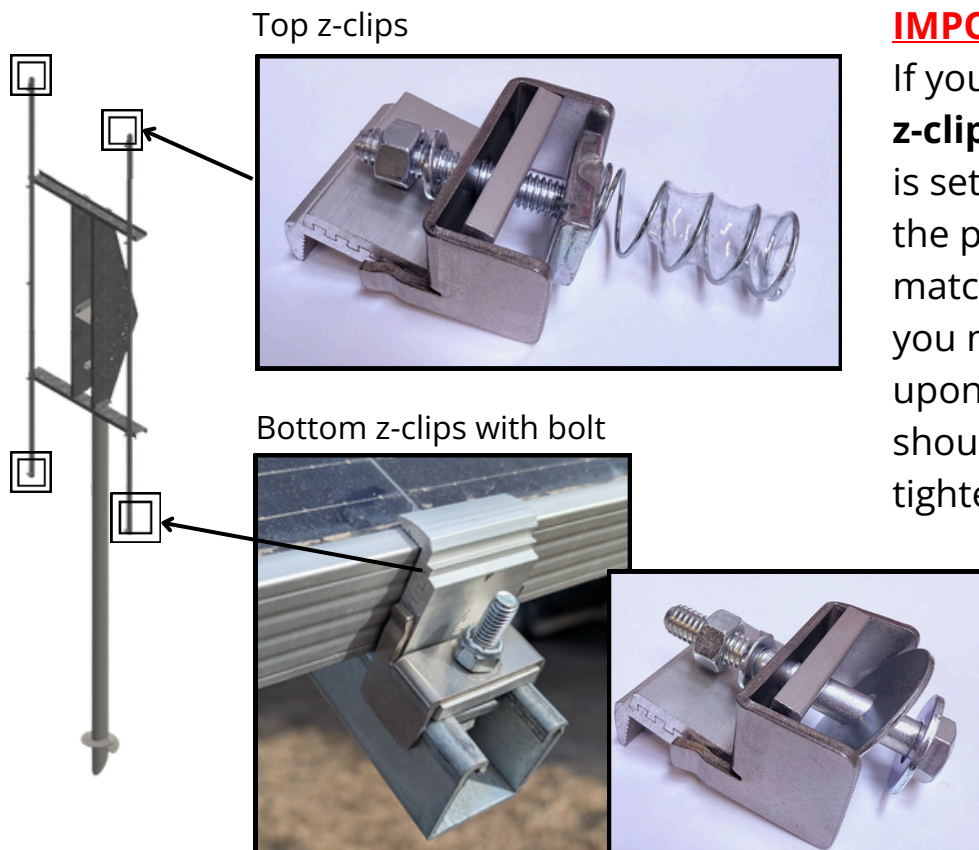

IMPORTANT:

If you have **adjustable z-clips** make sure the z-clip is set to the thickness of the panel. If it does not match the panel thickness, you may crack the panel upon tightening. Clip should just be snug after tightening.

Depending on the solar panel used you may wish to trim excess purlin length on top and or bottom, but excess purlin length may be left as is..

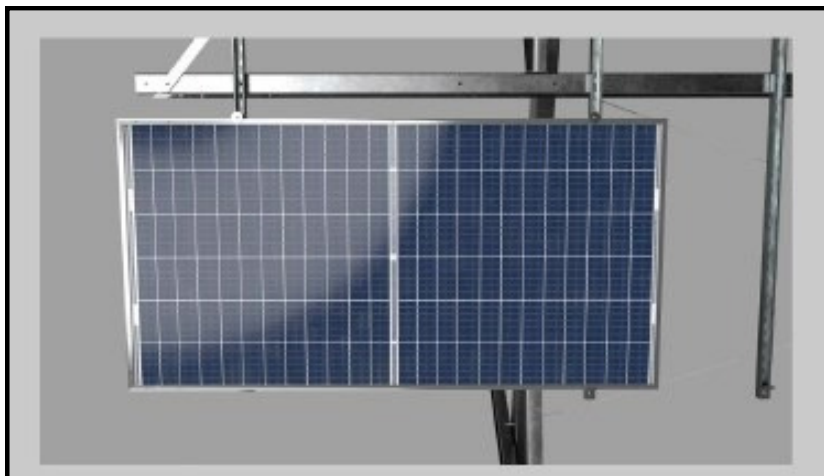

Panel Bolting Detail

Bonding washers may be used if bonding is required. Bonding washer only required on one purlin column of panels.

MP-4

1 column
4 panels

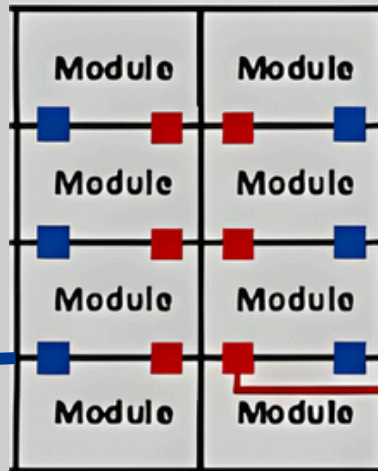

MP-8

2 columns
8 panels



Bonding Washer

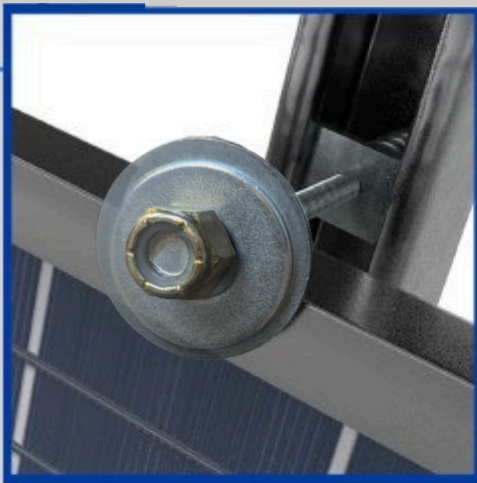

**No bonding washer.
Fender washer on top only.**



**Bonding washer inserted between
solar panels and bottom fender
washer**

- Spring-bolts with 3/8" x 2-1/2" studs, placed into the purlins,
- A 3/8" fender washer,
- An AKS bonding washer,
- Two solar modules placed - one of either side of the protruding stud,
- A fender washer placed on to the stud,
- A 7/16" flat washer
- A 3/8" Nyloc nut installed and torqued to **12-15lbs.** -ft once solar panels are in position on each side of the fastener.
- **IMPORTANT: DO NOT OVER-TIGHTEN THE PANEL NUTS. Overtightening may shatter the solar panel.**

Solar Module Installation

Spring Clip Installation Note:

IMPORTANT! When installing the solar panels on top of the spring clip bolt, sliding the panels along the spring clip bolt may cause the bolt to turn and unlock from the purlin below.

After installing the washer and nut on the spring clip bolt, **check that the length of the bolt is consistent with the others. Pull on the solar panel to be sure the spring clip bolt is locked in place.**

The solar panel will lift off if the spring clip bolt is not seated correctly.



If the clip has popped out of the purlin, you will be able to tell as the spring clip bolt will be protruding out further.



The clip should remain within the trench of the purlin.

Thank you for your purchase!
If you have any questions regarding these instructions, please contact our office

Patrick Fulawka

Office: (403) 236-5501

Cell: (403) 815-8515

Email: pfulawka@azgard.com

Office Address:

Unit 2, 34 Wrangler Pl SE

Calgary, AB T1X 0L7

Email: info@azgard.com

